



3-CHANNEL RGB LED LAMP DRIVER

GENERAL DESCRIPTION

The M13551 is a 3-channel PWM enabled current sink driver for RGB LED or display applications. Tri-state data format designed for single wire transmit data and clock. It is easy to be designed in applications that need mixing RGB light sources for multi-color output. The output current is determined by an external resistor and the brightness control code, both set by users.

FEATURES

- CMOS technology.
- Single wire series transmit data
- 3 output channels for RGB LED lamps.
- Output current invariant to load voltage change.
- 8-bits luminance data with PWM current output.

APPLICATIONS

- LED Decorative Lighting.
- PWM Signal Generator.
- Keypad back lighting

BLOCK DIAGRAM

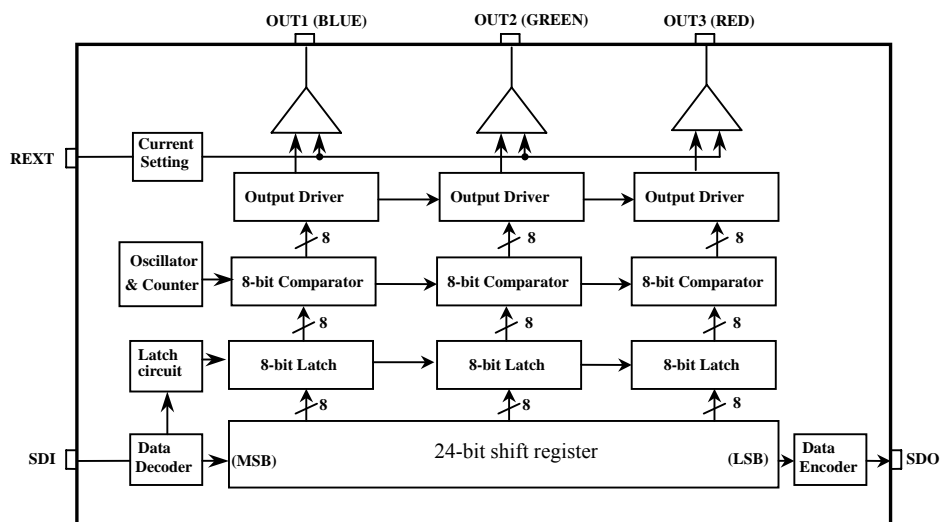



3-CHANNEL RGB LED LAMP DRIVER

PIN ASSIGNMENT

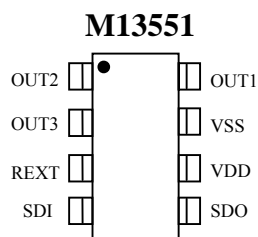

PIN DESCRIPTION

NO.	Pin Name	Type	Description
1	OUT2	OUTPUT	NMOS Output Driver(open-drain)
2	OUT3	OUTPUT	NMOS Output Driver(open-drain)
3	REXT	INPUT	External Resistor For Setting Up Output Current For All Output Channels
4	SDI	INPUT	Serial Data Input
5	SDO	OUTPUT	Serial Data Output
6	VDD	POWER	Positive power supply
7	VSS	GND	Negative power supply
8	OUT1	OUTPUT	NMOS Output Driver(open-drain)



3-CHANNEL RGB LED LAMP DRIVER

ABSOLUTE MAXIMUM RATINGS

Characteristics	Symbol	Rating	Unit
Supply Voltage	V_{DD}	3.5 ~ 6	V
Logic Input Voltage	V_{IN}	-0.3 ~ +0.3	V
Clock Frequency	F_{CLK}	660	KHz
Output Sustaining Voltage	V_{DS}	6	V
Output Continuous Current, Each Channel	I_{OUT}	20	mA
Power Dissipation, Each Channel	P_{DISP}	100	mW
Operating Temperature	T_{OPR}	-20 ~ +85	°C
Storage Temperature	T_{STR}	-60 ~ +150	°C

ELECTRICAL CHARACTERISTICS

($V_{DD}=5V$, $T_a=25^\circ C$, Unless Otherwise Specified)

Characteristics	Symbol	Condition	Min.	Typ.	Max.	Unit	
Supply Voltage	V_{DD}	—	3.3	5.0	5.5	V	
Output Voltage	V_{DS}	OUT1, OUT2, OUT3 terminals	—	—	5.5	V	
Output Current	I_{OUT}	DC Test Circuit	—	18	—	mA	
Input Voltage	“H” level	V_{IH}	$T_a = -20\sim 85^\circ C$	$0.7 V_{DD}$	—	V_{DD}	V
	“L” level	V_{IL}	$T_a = -20\sim 85^\circ C$	0	—	$0.3 V_{DD}$	V
Output Leakage Current	I_{OH}	$V_{OH} = 5.0V$	—	0	—	μA	
OUT1	I_{OUT1}	$G_{BLUE} = (1,1,1,1,1,1,1,1)$	—	18	—	mA	
OUT2	I_{OUT2}	$G_{GREEN} = (1,1,1,1,1,1,1,1)$	—	18	—	mA	
OUT3	I_{OUT3}	$G_{RED} = (1,1,1,1,1,1,1,1)$	—	18	—	mA	
Current Skew	ΔI_{OUT}	$I_{OUT} = 18mA$ $V_{DS} = 1.0V$	—	± 10	—	%	
Output Current Variation vs. Supply Voltage Variation	—	V_{DD} within 2.7V and 3.3V	—	± 20	—	%	
		V_{DD} within 4.5V and 5.5V	—	± 10	—		
Supply Current	“OUT Off”	$I_{DD} (Off) 1$	OUT1~OUT3 = Off, $V_{DD} = 3.3V$	—	1	2	mA
	“OUT On”	$I_{DD} (Off) 1$	OUT1~OUT3 = On, $V_{DD} = 3.3V$	—	1	2	
	“OUT Off”	$I_{DD} (Off) 1$	OUT1~OUT3 = Off, $V_{DD} = 5V$	—	2	3	
	“OUT On”	$I_{DD} (Off) 1$	OUT1~OUT3 = On, $V_{DD} = 5V$	—	2	3	



3-CHANNEL RGB LED LAMP DRIVER

LED Current VS Vds

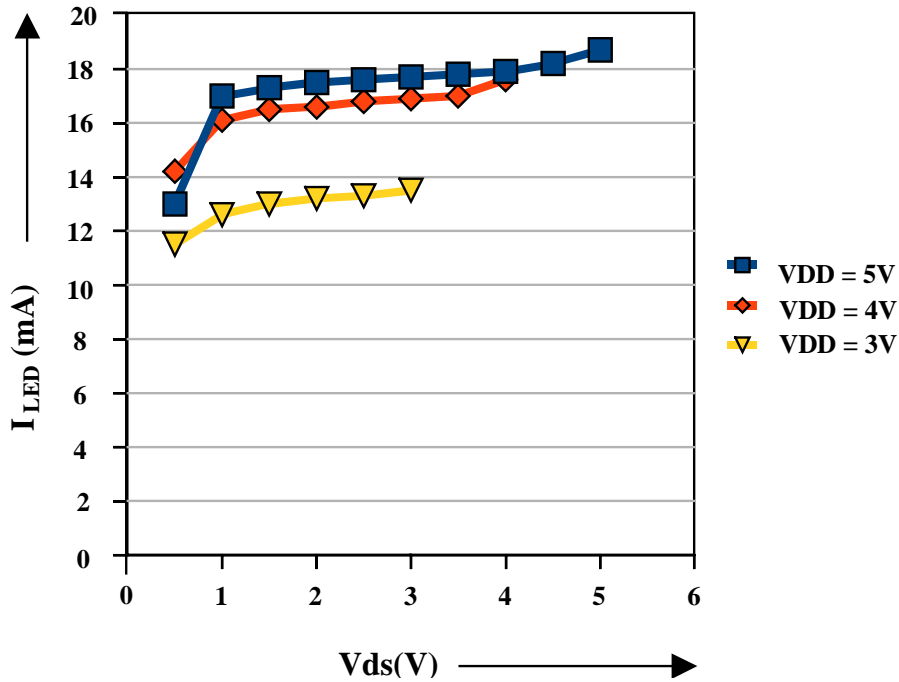

TIMING CHART & CONDITION

(1) DATA FORMAT

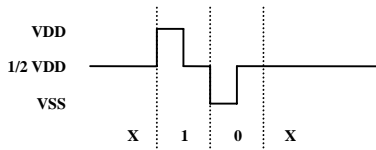

(2) TIMING DIAGRAM

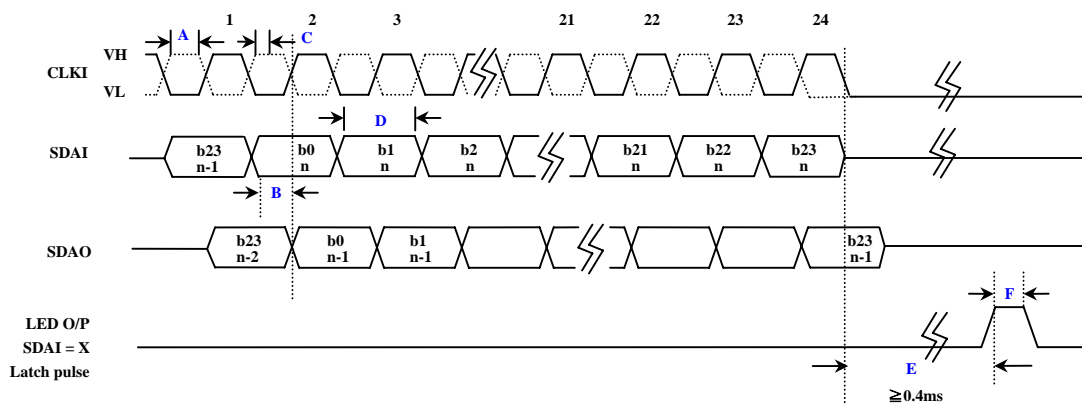



3-CHANNEL RGB LED LAMP DRIVER

(VDD=+5V, Ta=25°C, unless otherwise specified)

Item	Description	Min	Typ	Max	Unit
A	Clock Pulse Width	50	—	—	ns
B	Serial Data Setup Time	10	—	—	ns
C	Serial Data Hold Time	10	—	—	ns
D	Serial Data Pulse Width	50	—	—	ns
E	Time Between Clock Activation And Latch	0.4	—	—	ms
F	Latch Pulse Width	50	—	—	ns

TRUTH TABLE

Serial Data Input	Clock Input	Shift Register Contents	Serial Data Output	Latch Contents
		I _N I _{N-1}I ₂ I ₁ I ₀		I _N I _{N-1}I ₂ I ₁ I ₀
H	↕	↓ H R _N R _{N-1}R ₃ R ₂ R ₁	↑ R ₁	
L	↕	↓ L R _N R _{N-1}R ₃ R ₂ R ₁	↑ R ₁	
┌ X		R _N R _{N-1}R ₂ R ₁ R ₀	R ₀	R _N R _{N-1}R ₂ R ₁ R ₀
		X XX X X	X	
		P _N P _{N-1}P ₂ P ₁ P ₀	P ₀	P _N P _{N-1}P ₂ P ₁ P ₀

Internal Oscillator Output	Counter Contents	Latch Contents	NMOS Output
	I ₇I ₂ I ₁ I ₀	I ₇I ₂ I ₁ I ₀	
X	LL L L	P ₇P ₂ P ₁ P ₀	If P > Q Then I _{DS} ON Else I _{DS} OFF
└	[Q ₇ : Q ₀]+1 Count Up		
┌	Q ₇Q ₂ Q ₁ Q ₀		

L=Low Logic Level H=High Logic Level X=Irrelevant
R=Previous State P=Present State Q=Counter State

3-CHANNEL RGB LED LAMP DRIVER

An Example

$V_{out} = 1.0V$ for OUT1 / BLUE, OUT2 / GREEN, and OUT3 / RED

If the 24-bit Configuration Code is {11111111, 00000000, 10000000},

$$I_{OUT1, BLUE} = G_{BLUE} / 255 = 255/255 \times 18mA = 18mA ;$$

$$I_{OUT2, GREEN} = G_{GREEN} / 255 = 0/255 \times 18mA = 0mA ;$$

$$I_{OUT3, RED} = G_{RED} / 255 = 128/255 \times 18mA = 9mA ;$$

The mixing multi-color is determined by $I_{OUT, GREEN} = 18mA$, $I_{OUT, RED} = 0mA$, and $I_{OUT, BLUE} = 9mA$.

Assuming Luminous Intensity (mcd) of R / G / B LEDs are the same and $I = 18mA$, we may ideally let

$G_{GREEN} + G_{RED} + G_{BLUE} = C$ (Constant value) to get a stable brightness.

For instance, while $C = 10$, that is $G_{GREEN} + G_{RED} + G_{BLUE} = 10$, M13551 can easily give system designers a wide range of color and brightness control in portable electronic devices.

TYPICAL APPLICATION

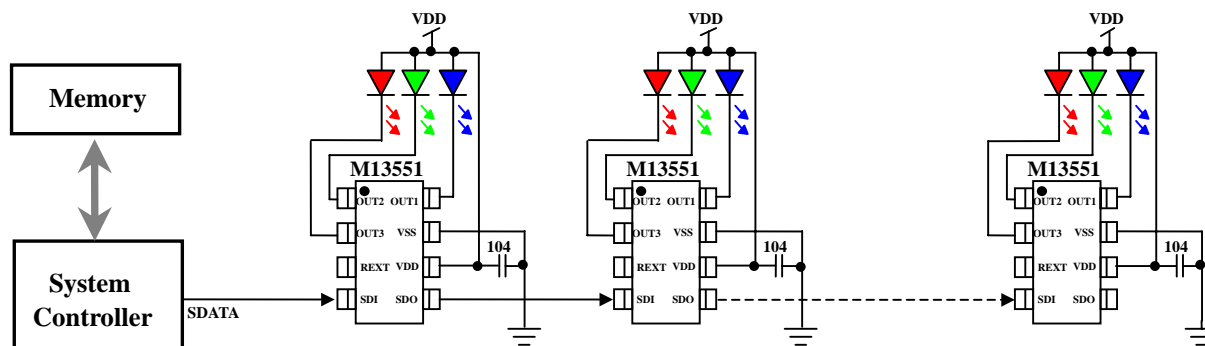

* All specs and applications shown above subject to change without prior notice.

(以上電路及規格僅供參考,本公司得逕行修正)



3-CHANNEL RGB LED LAMP DRIVER

PACKAGE OUTLINE

8-Pin Plastic SOP

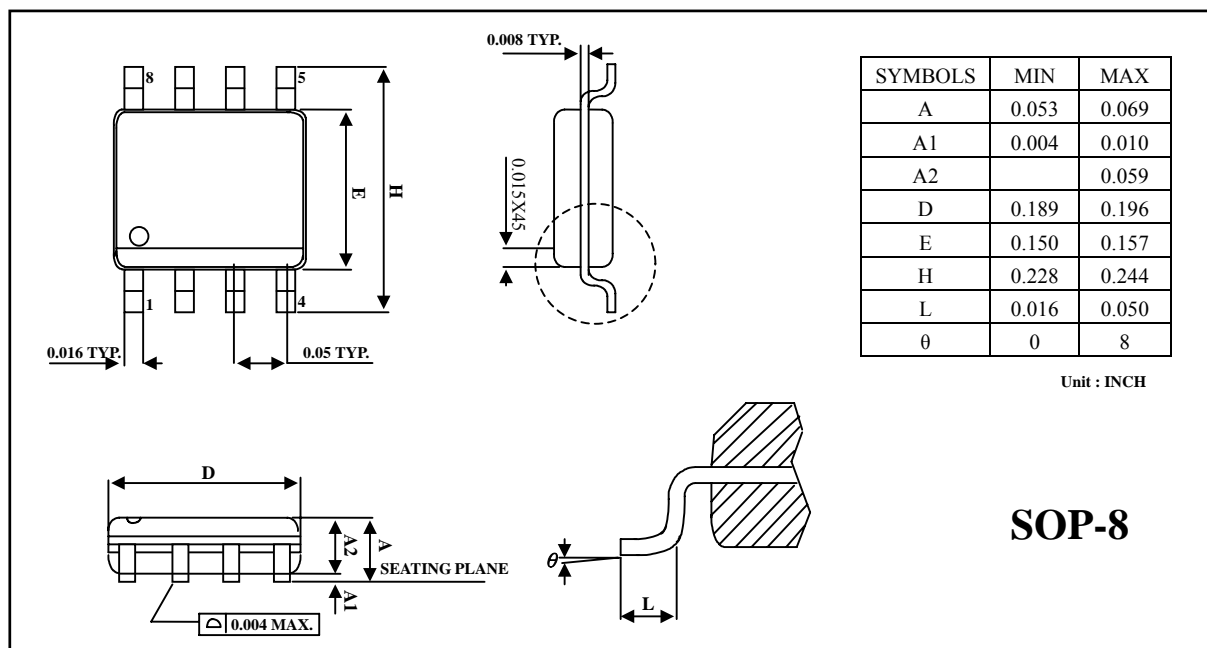

* All specs and applications shown above subject to change without prior notice.

(以上電路及規格僅供參考,本公司得逕行修正)