



REMOTE FAN CONTROLLER

遙控風扇控制器 IC

GENERAL DESCRIPTION 功能叙述

The M78206 is an electronic fan controller. It includes speed control, off timer, rhythm wind, sleep mode, head swing, light control, buzzer output and key control input function, supports two-bit customer codes.

FEATURES 产品特长

- Middle wind start-up.
- 3 or 4 steps timer setting.
- 2 swing head control.
- A dependent SLEEP key with timer setting automatically.
- SP or ON/OFF key can enable fan controller.
- Memory start-up function.
- Panel control or combine with M75104 for an infrared remote fan controller.
- 18/20/22 pin plastic DIP package.

APPLICATIONS 产品应用

- Fan Remote Control...

BLOCK DIAGRAM 功能方块图

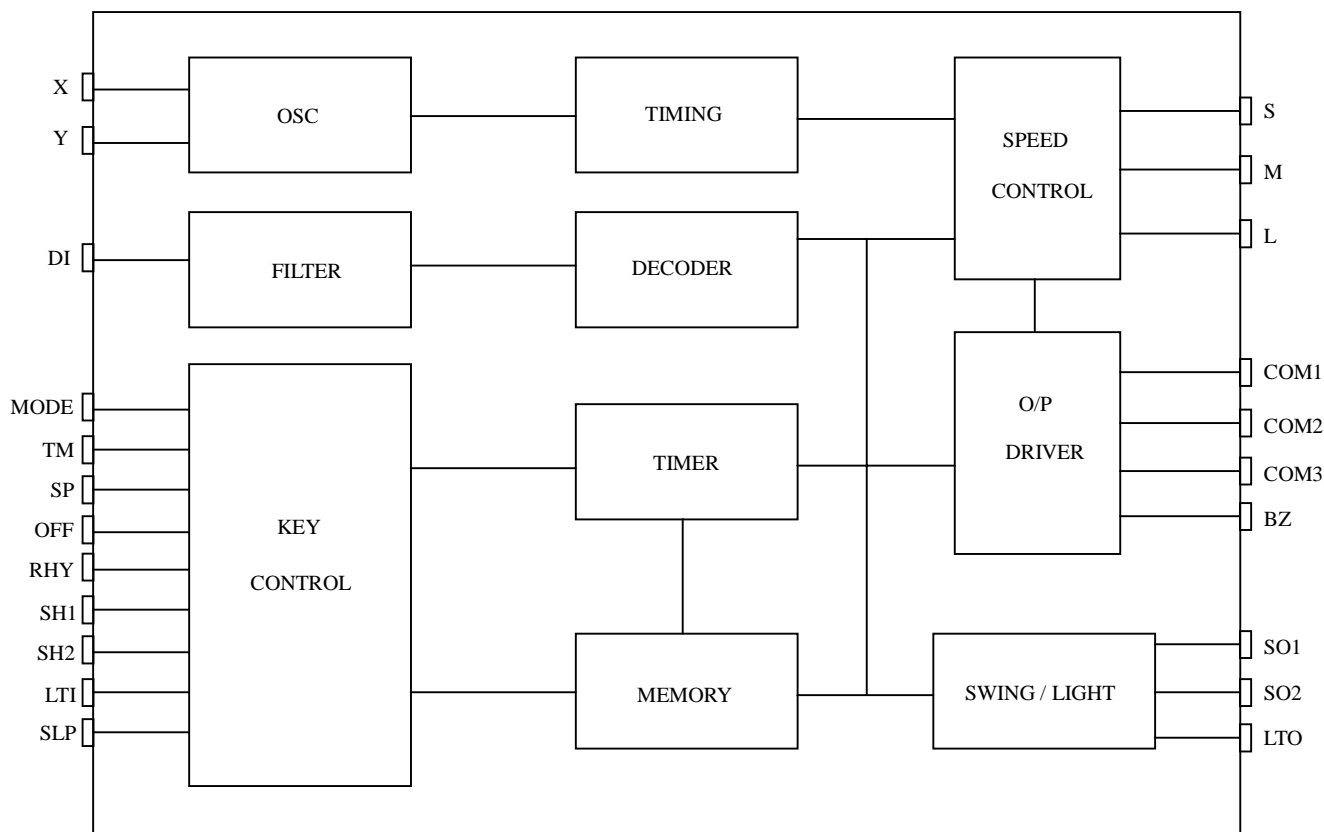

*All specs and applications shown above subject to change without prior notice.
(以上电路及规格仅供参考,本公司得径行修正)



REMOTE FAN CONTROLLER

遙控風扇控制器 IC

M78206

ABSOLUTE MAXIMUM RATING

(TA=25°C)

Parameter	Rating	Unit
Supply Voltage	-0.3 to 6.0	V
Input Voltage	-0.2~V _{DD} +0.2	V
Operating Temperature	0 to 60	°C
Storage Temperature	-25 to 125	°C

ELECTRICAL CHARACTERISTICS

Characteristics	Sym.	Min.	Typ.	Max.	Unit	Conditions
Operating Voltage	V _{DD}	—	3	—	V	
Quiescent Current	I _{SB}	—	1	5	μA	
Operating Current	I _{OP}	—	0.1	0.5	mA	No load
Buz Source Current	I _{OH}	—	5	—	mA	@V _{DS} = 4.3V
	I _{OL}	—	10	—		@V _{DS} = 0.7V
Triac Sink Current (S,M,L,SH1,SH2 LTD)	I _{OL}	—	10	—	mA	@V _{DS} = 0.7V
Source Current (OFF,MODE,SP,TM)	I _{OH}	—	10	—	mA	@V _{DS} = 4.3V
Sink Current (COM1~COM3)	I _{OL}	—	40	—	mA	@V _{DS} = 0.7V
Oscillator Frequency	F _{OSC}	—	455	—	KHz	± 30% TOL.

PIN DESCRIPTION

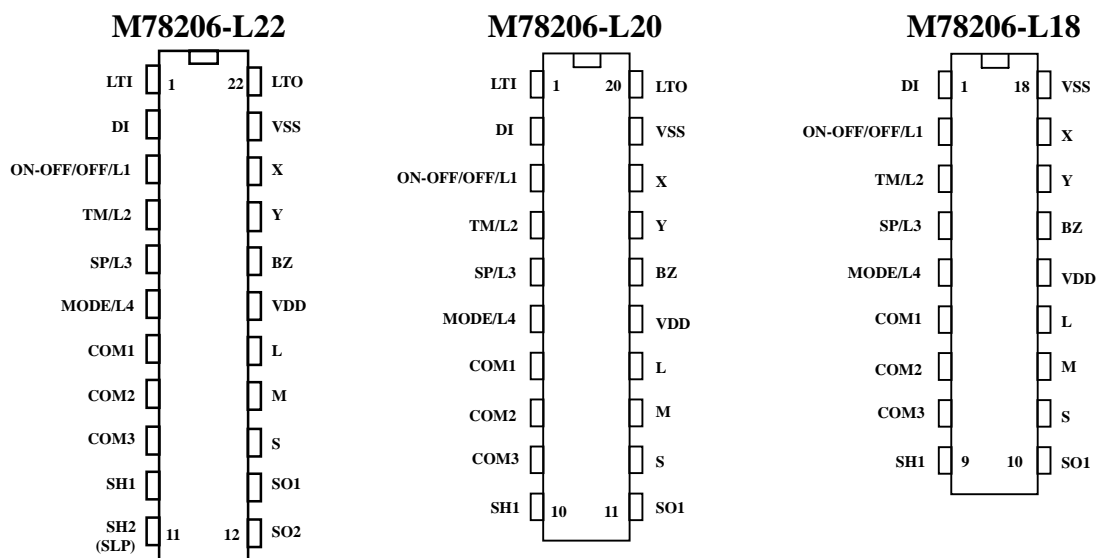



REMOTE FAN CONTROLLER

遙控風扇控制器 IC

M78206

PAD DESCRIPTION

No.	PIN	FUNCTION
1	LTI	Light control input
2	DI	Remote control input
3	ON-OFF/OFF/L1	ON-OFF or OFF function control input and LED output
4	TM/L2	Timer setting input and LED output
5	SP/L3	Wind grade selection input and LED output
6	MODE/L4	Wind mode selection input and LED output
7	COM1	LED scanning common pin/custom code
8	COM2	LED scanning common pin/custom code
9	COM3	LED scanning common pin
10	SH1	Swing head control input/customer code
11	SH2	Swing head control input
	SLP	Swing head control input
12	SO2	Sleep key input
13	SO1	Swing head/tuner pulse output
14	S	Wind speed control output
15	M	Wind speed control output
16	L	Wind speed control output
17	VDD	Positive power supply
18	BZ	Trigger output to drive piezo
19	Y	Crystal output
20	X	Crystal input
21	VSS	Negative power supply
22	LTO	Light control output



REMOTE FAN CONTROLLER

遙控風扇控制器 IC

APPLICATION DIAGRAM 參考電路圖

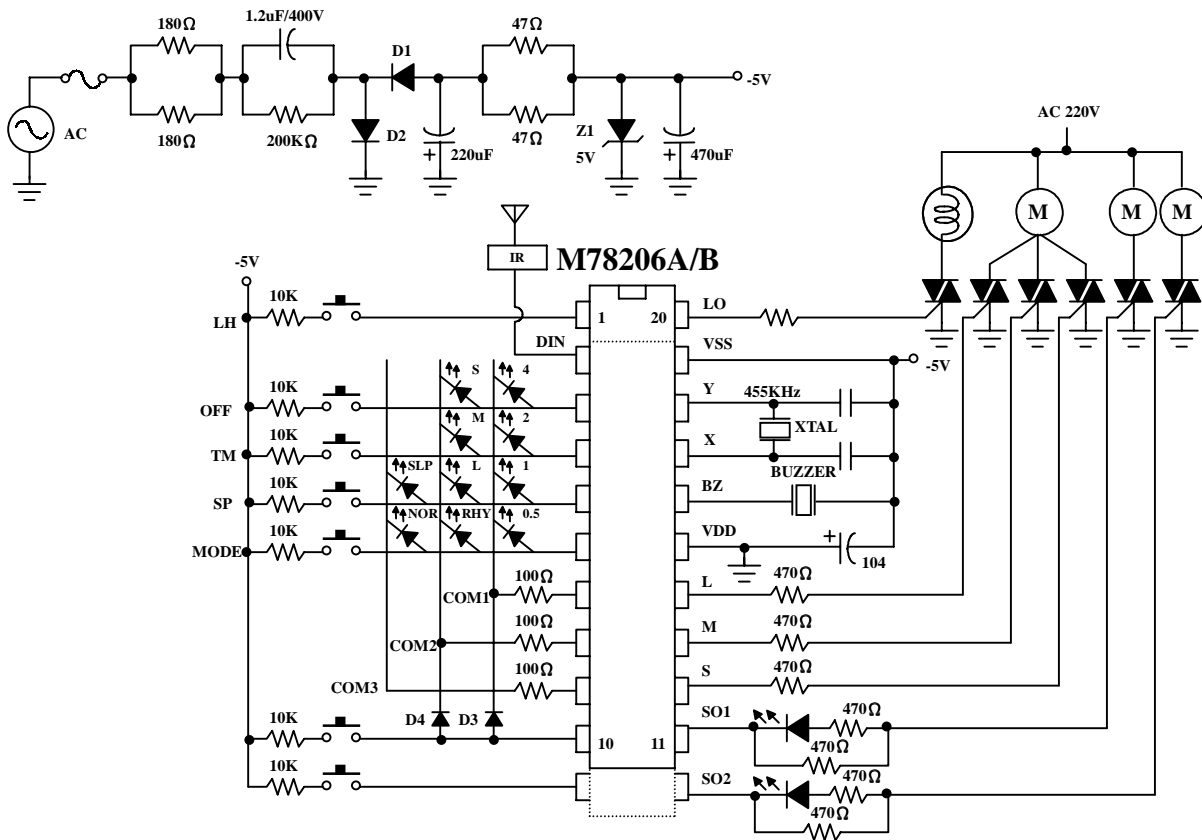

D3,D4 : Custom code
"0" : Open
"1" : Connect the diode



SAMPLE CONTROL PANEL LAYOUT

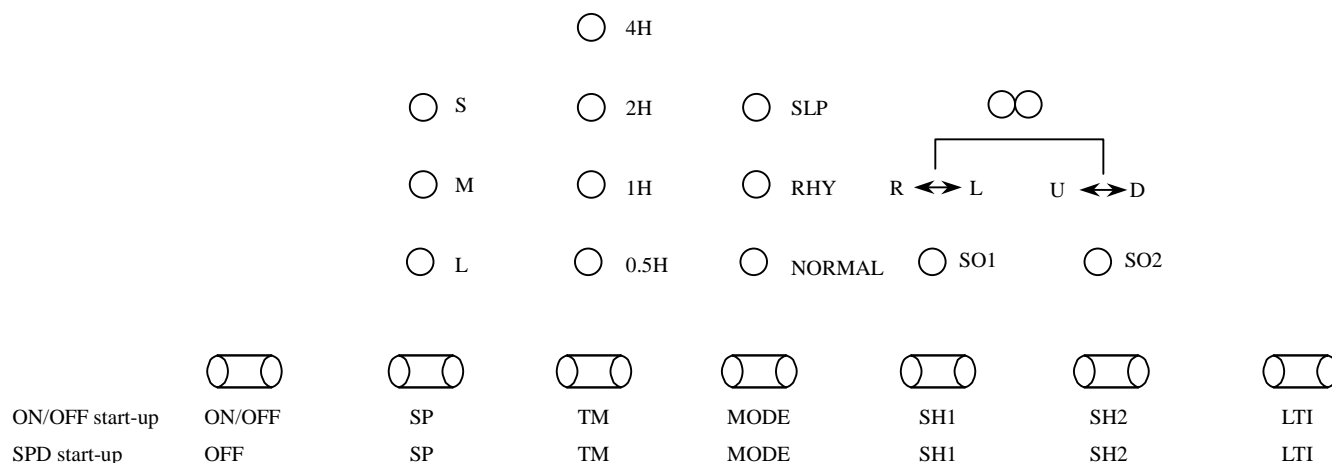

OPERATION

M78206 has two control types : panel keypad and infrared remote control.
Only SP or ON/OFF key can enable the fan controller.

- Start-up by SP key
 - 1.function turn off (OFF key)
 - 2.wind mode select (MODE key)
 - 3.start-up function and wind speed select (SP key)
 - 4.timer setting (TM key)
 - 5.swing head or tuner for swing angle (SH1 and SH2 key)
 - 6.lighting control (LTI key)
 - 7.sleep mode setting directly(SLP key / M78206 only)
- Start -up by ON/OFF key
 - 1.function control (ON/OFF key)
 - 2.wind mode select (MODE key)
 - 3.wind speed select (SP key)
 - 4.timer setting (TM key)
 - 5.swing head or tuner for swing angle (SH1 and SH2 key)
 - 6.lighting control (LTI key)
 - 7.sleep mode setting directly (SLP key / M78206 only)

If the panel keys are pressed more than 6 seconds, controller will generate a “Bi-Bi-Bi-Bi” warning sound.



OFF KEY

- (1) When fan controller is on, press the OFF key on panel or remote control handset, fan functions will be turned off except light output.
- (2) ON/OFF key (option) : when fan controller functions are on, press ON/OFF key on function will be turned are off, press the key to turn on fan functions, light output is indepent.

SP KEY

● Start-up SP key

When fan controller is off, press SP key on panel or remote control handset, fan is turned on, initial state is LOW wind; when memory function is available, the wind grade will operate as last state. Both conditions have three seconds starting wind. Press the SP key again, the wind will be changed as follows :

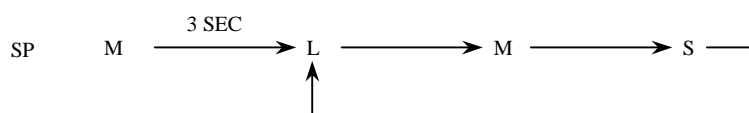

● Start-up by ON/OFF key (option)

If fan controller is off, SP key cannot be used, must press ON/OFF key to turn on the fan controller.

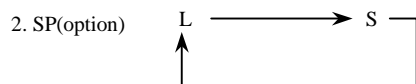
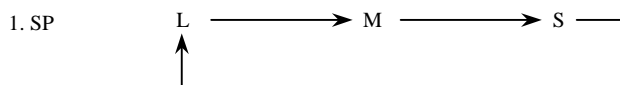

MODE KEY

Three types of wind mode : normal, rhythm and sleep.

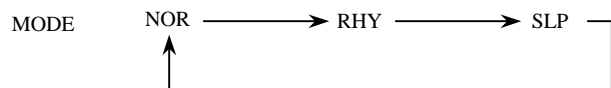

M78206 :

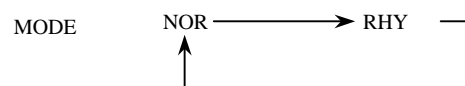
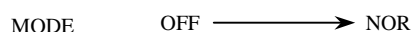



REMOTE FAN CONTROLLER

遙控風扇控制器 IC

M78206

LTI KEY

The LTI key is independent and the output is toggle function.



TM KEY

Mode “A” is accumulation and mode “N” NON-accumulation for three or four steps.

- (1) A4 : 0.5, 1, 2, 4 four steps accumulation
- (2) N3 : 1, 2, 4 three steps NON-accumulation

SWING KEY : SH1 and SH2

The swing key will not activate when fan controller is off.

M78206A :

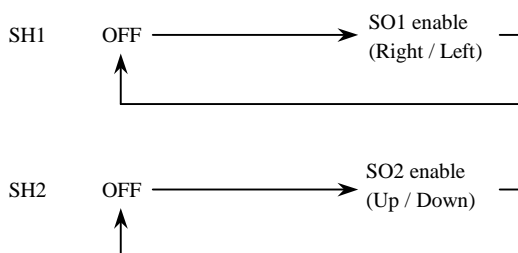

When SH1 and SH2 output enable together, the swing head has 3D function.

M78206B

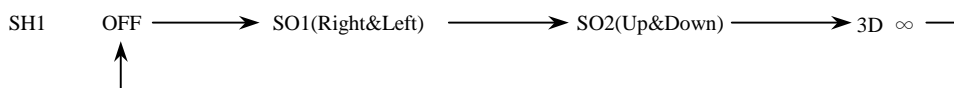

MEMORY FUNCITON

If last state is sleep mode, press SP or ON/OFF key enable fan controller

While memory functions (SPEED/MODE/SWING) will be returned to the last state before sleep mode operation.



REMOTE FAN CONTROLLER

遙控風扇控制器 IC

CUSTOMER CODE

M78206, provide two-bit customer code. There are four types, that can be set by diode.

- a. set code bit to "1", connect diode to COM1/COM2 and SH1 terminal
- b. set code bit to "0", open the circuit

D1	D2
0	0
0	1
1	0
1	1

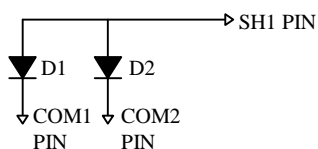

BUZZER

- a. when FAN is from stop mode to start mode

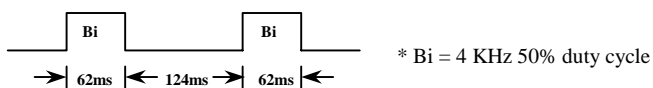

- b. when FAN is from start mode to stop mode

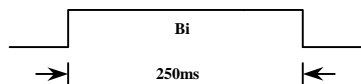

- c. when FAN is operating

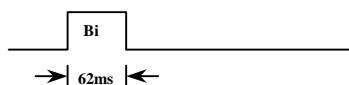



REMOTE FAN CONTROLLER

遙控風扇控制器 IC

RHYTHM WIND FUNCTION

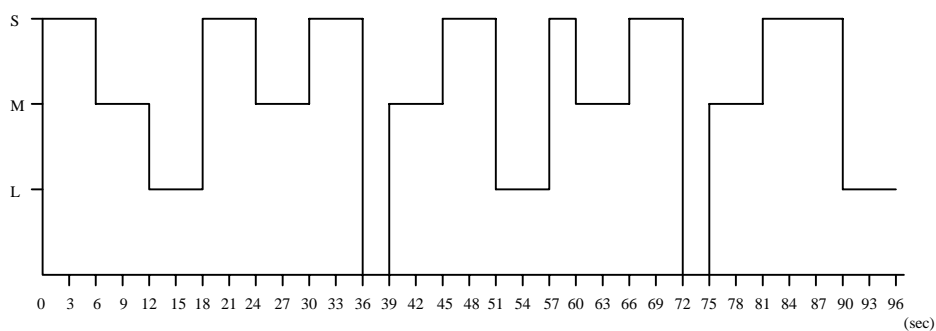

STRONG RHYTHM WIND PATTERN

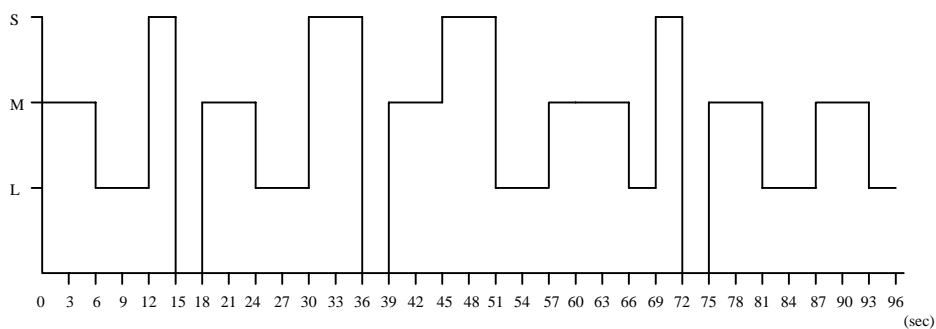

MEDIUM RHYTHM WIND PATTERN

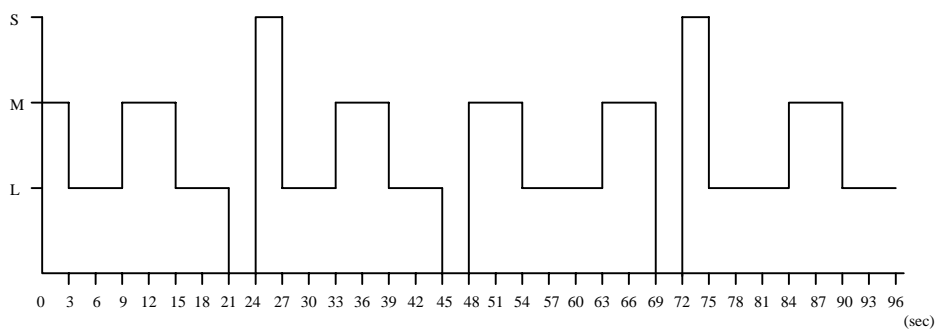

LOW RHYTHM WIND PATTERN



REMOTE FAN CONTROLLER

遙控風扇控制器 IC

SLP KEY

1. Rhythm wind sleep function

Wind grade is changed by timing automatically.

(1) STRONG rhythm sleep :

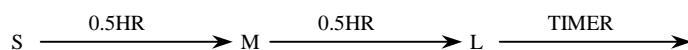

(2) MEDIUM rhythm sleep :



(3) LOW rhythm sleep :



2. Normal wind sleep function

Wind grade is changed by timing automatically.

(1) STRONG normal sleep :

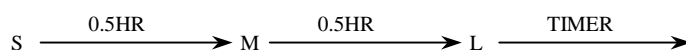

(2) MEDIUM normal sleep :



(3) LOW normal sleep :

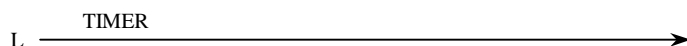



REMOTE FAN CONTROLLER
遙控風扇控制器 IC

M78206

ORDERING INFORMATION

