

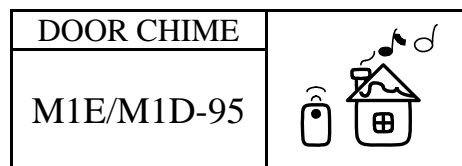

DUAL TONE
WIRELESS DOOR BELL

遥控门铃 IC



FEATURES 功能叙述

- 3 door chime sound.

M1D-95
D2 WEST MINISTER
D1 DING DING
D0 DING DONG

APPLICATION 产品应用

- Door bell system. 门铃系统.

ELECTRICAL CHARACTERISTICS 电气规格

(@V_{DD}=4.5V unless otherwise specified)

Characteristics	Sym.	Min.	Typ.	Max.	Unit	REMARKS
工作电压 Operating Voltage	V _{DD}	2.4	4.5	5	V	
工作电流 Operating Current	I _{OP}	—	0.3	1	mA	No load
静态电流 Quiescent Current	I _{SB}	—	1	10	μ A	
推动电流 Driving Current	I _{OL}	1	—	—	mA	@ V _{DS} =1.2V
振荡频率 Oscillator Frequency	F _{OSC}	—	80	—	KHz	External ± 30%
工作温度 Operating Temperature	Temp.	0	25	60	°C	

APPLICATION DIAGRAM 参考电路图

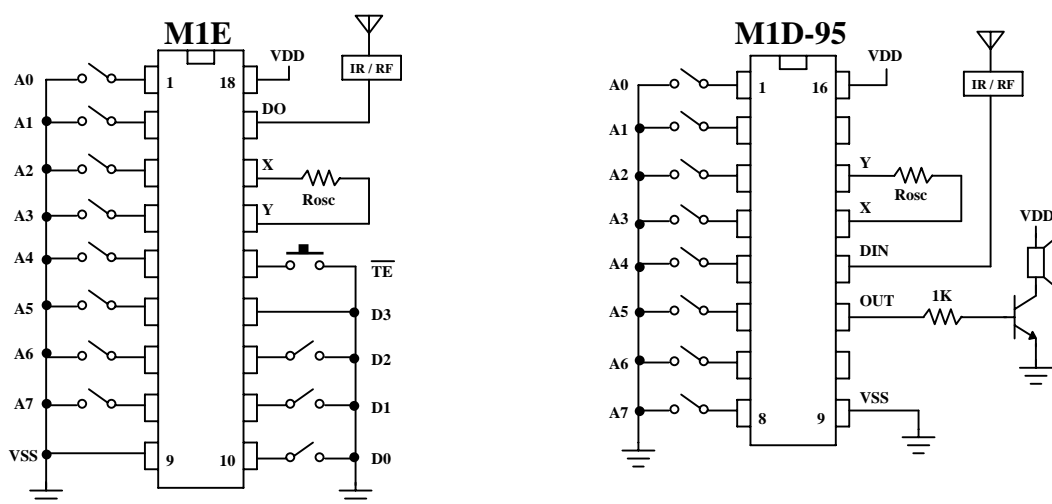

* Rosc ~ M1E: 200K Ω ; M1D-95: 390K Ω



DUAL TONE
WIRELESS DOOR BELL

遙控門鈴 IC

DOOR CHIME	
M1E/M1D-95	

APPLICATION DIAGRAM 参考電路圖

CHIP FORM

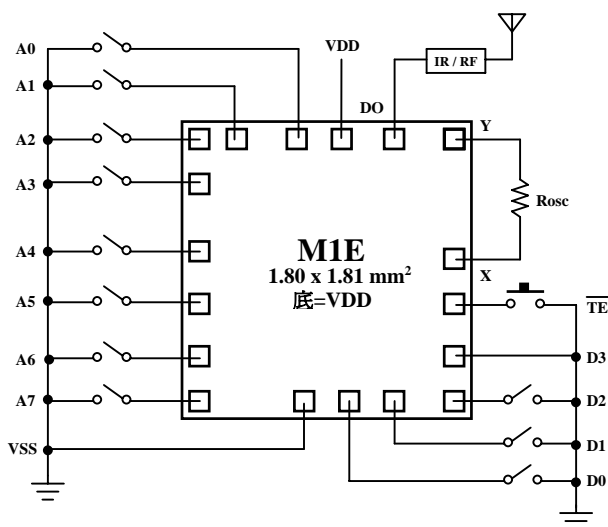

SOUND	
D2	WEST MINISTER
D1	DING DONG
D0	DING DONG

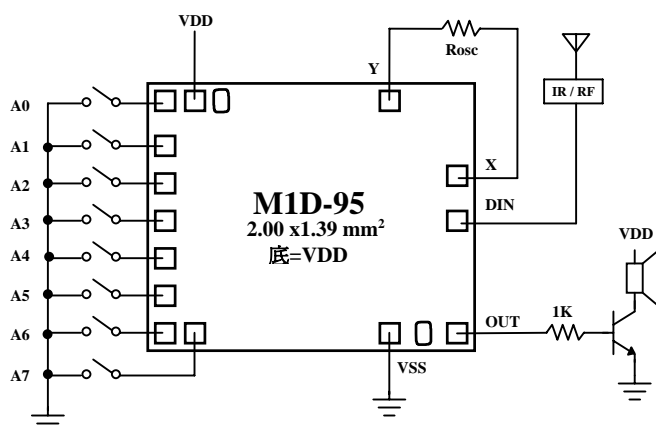

* Rosc ~ M1E: 200K Ω ; M1D-95: 390K Ω

*All specs and applications shown above subject to change without prior notice.

(以上電路及規格僅供參考,本公司得徑行修正)



DUAL TONE
WIRELESS DOOR BELL

遙控門鈴 IC

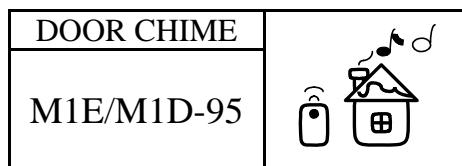

ASSIGNMENT & POSITION

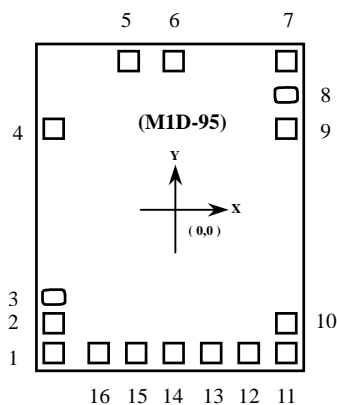

UNIT : um

No.	NAME	X	Y
1	A0	-561	-870
2	VDD	-560.25	-723.75
3	TEST3	-562.5	-585.75
4	OSC2	-560.25	537
5	OSC1	-317.25	870
6	DIM	-163.5	869.25
7	BZ	559.5	869.25
8	TEST	559.5	636.75
9	VSS	559.5	480
10	A7	559.5	717.75
11	A6	559.5	-872
12	A5	379.5	-867.75
13	A4	198.75	-867.75
14	A3	23.25	-868.5
15	A2	-150	-867.75
16	A1	-325.5	-868.5

* CHIP SIZE ~ 2.00 x 1.39 mm²

* IC substrate should be connected to VDD in PCB (PCB 上 IC 必須接 VDD)