



POWER
M8128

POWER FACTOR CORRECTION CONTROLLER

GENERAL DESCRIPTION

The M8128 provides simple and high performance active power factor correction. The M8128 provides a controlled on-time to regulate the output DC voltage and achieve natural power factor correction. The maximum on-time of the external switch is programmable to ensure safe operation during AC brownouts. An innovative multi-vector error amplifier is built in to provide rapid transient response and precise output voltage clamping. A built in circuit will disable the controller if the output feedback loop is opened.

FEATURES

- Low Input Current THD
- Controlled On-Time PWM
- Zero-Current Detection
- Leading-Edge Blanking instead of RC Filtering
- Low Start-up Current
- Low Operating Current
- Transition mode operation
- Under Voltage Lockout with Hysteresis
- Feedback Open Loop Protection
- Programmable Maximum On-Time
- 8-pin DIP or 8-pin SOP

APPLICATIONS

- Electronic Lamp Ballasts
- AC-DC Switching Mode Power Converters
- Open Frame Power Supplies and Power Adapters
- Flyback Power Converters with ZCS/ZVS

PIN ASSIGNMENT

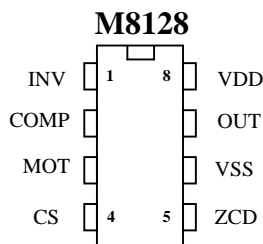



POWER
M8128

POWER FACTOR CORRECTION CONTROLLER

BLOCK DIAGRAM

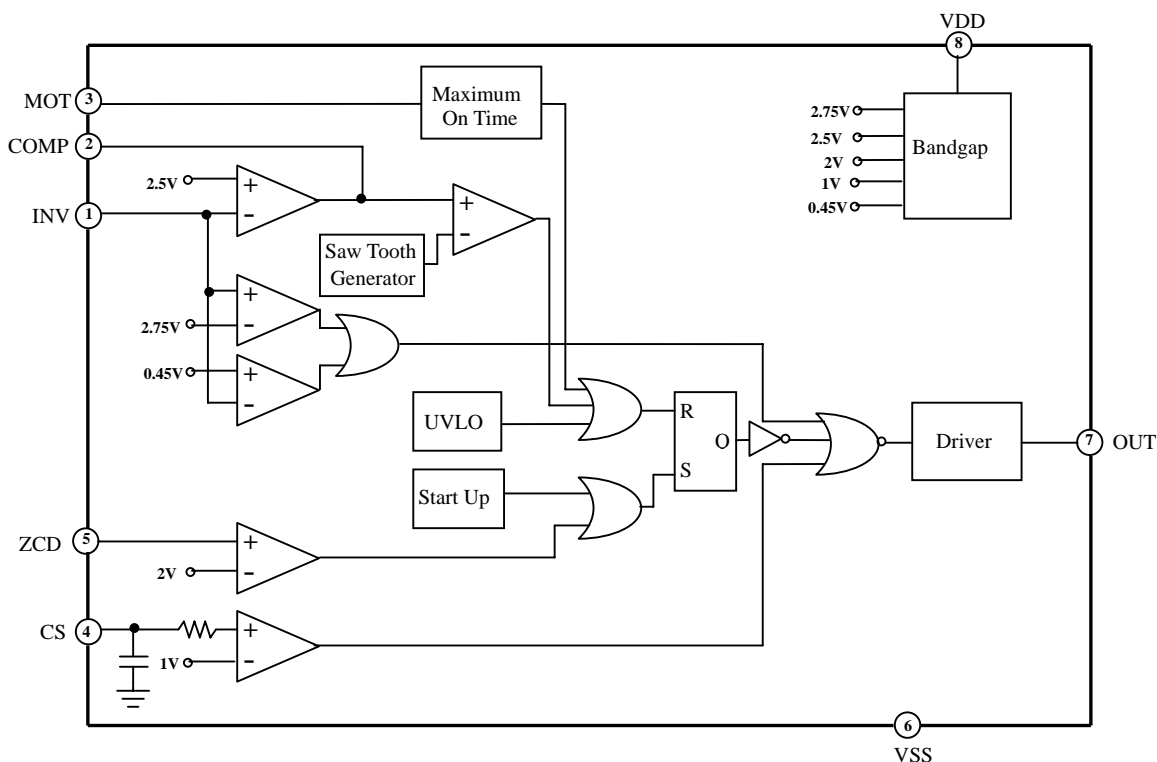

PIN DESCRIPTION

Pin No	Pin Name	Description
1	INV	Inverting input of the error amplifier. INV is connected to the converter output via a resistive divider. This pin is also used for over-voltage clamping and open loop feedback protection.
2	COMP	The output of the error amplifier. In order to create a precise clamping protection, a compensation network between this pin and VSS is suggested.
3	MOT	A resistor from MOT to VSS is used to determine the maximum on-time of the external power MOSFET. The maximum output power of the converter is a function of the maximum ON-time.
4	CS	Input to the over-current protection comparator. When the sensed voltage across the sense resistor reaches the internal threshold, the switch will be turned off to activate cycle-by-cycle current limiting.
5	ZCD	Zero current detection input.
6	VSS	The ground potential of all the pins.
7	OUT	Totem-pole Gate driver output. The push pull output stage is able to drive the Power MOSFET with peak current of 500mA.
8	VDD	Supply voltage of driver and control circuits.



POWER FACTOR CORRECTION CONTROLLER

ABSOLUTE MAXIMUM RATINGS

Parameter	Symbol	Test Condition	Value	Unit
Supply Voltage	VDD		12	V
OUT	V _{HIGH}		-0.3 to 14	V
Others (INV, COMP, MOT, CS,)	V _{LOW}		-0.3 to 7	V
Input Voltage to CS Pin	V _{CS}		-0.3 to 12	V
Power Dissipation	P _D	at TA < 50°C	800	mW
Storage Temperature Range	T _{STG}		-65 to +150	°C

* All voltage values, except differential voltages, are given with respect to VSS pin.

* Stresses beyond those listed under "absolute maximum ratings" may cause permanent damage to the device.

ELECTRICAL CHARACTERISTICS

(VDD= 12V, TA = -20°C~125°C, unless noted)

Parameter	Symbol	Test Condition	Min.	Typ.	Max.	Unit
Under Voltage Lockout Section						
Continuously Operating Voltage	V _{OP}			12	14	V
Start Threshold Voltage	V _{th} (st)	VDD increasing	8.5	9.5	11.0	V
UVLO Hysteresis	HY (st)	--		2.5	3	V
Supply Current Section						
Start-Up Current	I _{CC-ST}	VDD= V _{TH-ON} -0.16V		250	300	uA
Operating Supply Current	I _{CC}	Output not switching	--	3	6	mA
Dynamic Operating Supply Current	I _{DCC}	50KHz, CI=1nF	--	4	8	mA
Error Amplifier Section						
Reference Voltage	V _{REF}		2.95	3.0	3.05	V
Over Voltage Protection for INV Input	V _{INV-OVP}		2.7	2.75	2.8	V
Under Voltage Protection for INV Input	V _{INV-UVP}		0.4	0.45	0.5	V
Source Current	I _{COMP}	V _{INV} =2.35V, V _{comp} =1.5	7	20		uA
Sink Current	I _{COMP}	V _{INV} =2.65V, V _{comp} =5	10	20		uA
Current Sense Section						
Threshold Voltage for Peak Current Limit Cycle by Cycle Limit	V _{PK}	V _{comp} =6V	0.75	0.80	0.85	V
Propagation Delay	T _{PKD}				200	nsec
Leading-Edge Blanking Time	T _{BNK}	R _{MOT} = 100K		400	500	nsec
Output Section						
Output Voltage Low	V _{OL}	VDD= 12V, IO = 100mA			4	V
Output Voltage High	V _{OH}	VDD= 12V, IO = 100mA	8			V
Rising Time	T _R	VDD=12V, CL=2000pf	50	80	160	nsec
Falling Time	T _F	VDD=12V, CL=2000pf	50	80	160	nsec
Zero Current Detection Section						
Input Threshold Voltage Rising Edge	V _{ZVD}		1.8	2.0	2.2	V
Maximum Delay from ZCD to Output Turn-On	T _{DEAD}	V _{comp} =6V, FSW=60KHz	100		400	nsec
Restart Time	T _{RESTART}	Output Turned Off by IDET	100	120	150	usec
Inhibit Time (Max. Switching Frequency limit)	T _{INHIB}	R _{MOT} =100K	1.5	2.5	3	usec
Maximum On-Time Section						
MOT Voltage	V _{MOT}		0.75	0.8	0.85	V
MOT Programming (resistor based)	T _{ON-MAX}	R _{MOT} =100K, V _{CS} =0, Comp=6V	18	20	22	usec



POWER
M8128

POWER FACTOR CORRECTION CONTROLLER

APPLICATION DIAGRAM

(Wide-range Mains)

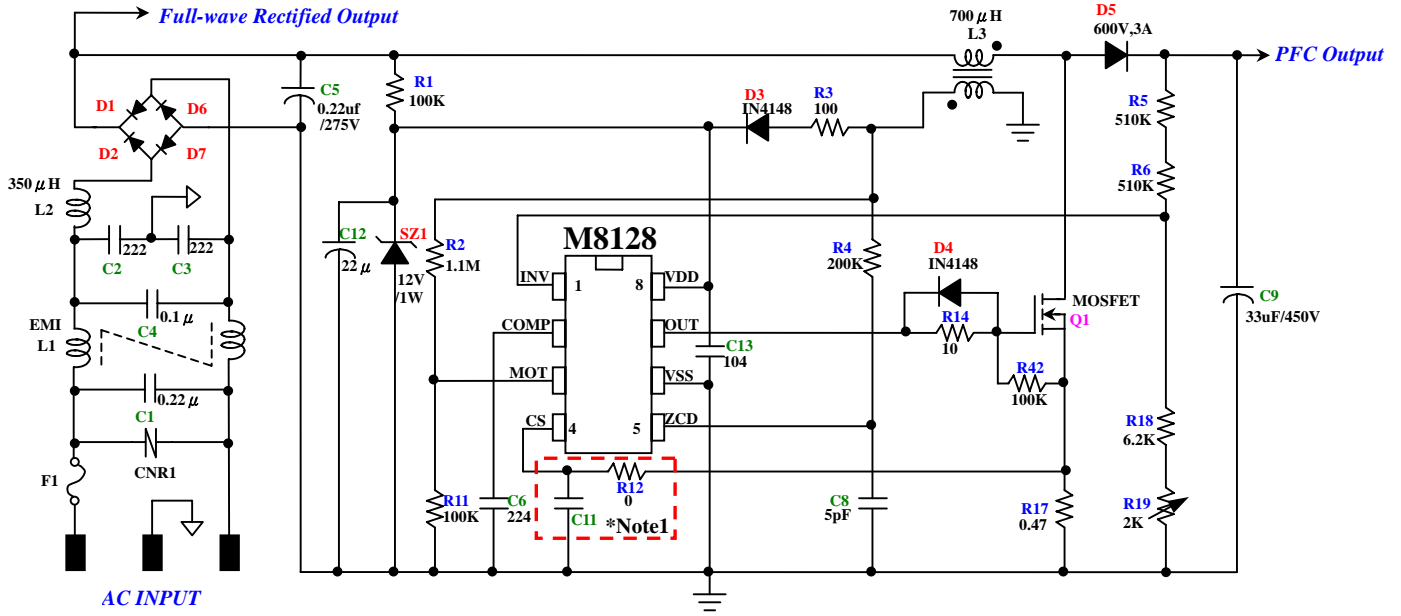

*Note1 : Compensation network between CS pin and VSS



POWER FACTOR CORRECTION CONTROLLER

COMPONENT LISTING

Designator	Value	Description	Quantity
C1, C5	0.22uF	BOX Capacitor, POLYPROPYLENE FILM Capacitor	2
C4	0.1uF	BOX Capacitor, POLYPROPYLENE FILM Capacitor	1
C2, C3	222	Y Capacitor	2
C6	224	Ceramic Capacitor	1
C8	5pF	Ceramic Capacitor	1
C9	33u/450V	Electrolytic Capacitor	1
C11	OPEN	Ceramic Capacitor	1
C12	22uF	Electrolytic Capacitor	1
C13	104	Ceramic Capacitor	1
CNR1	10D511K	Varistor	1
D1, D2, D6, D7	1N4007	Diode 1000V, 1A	4
D3, D4	1N4148	Diode 75V,1A	2
D5	HER306	Diode HIGH EFFICIENCY RECTIFIERS 600V, 3A	1
F1	3.15A/250V	Fuse	1
L1		EE19 Inductor	1
L2	350uH	DR1012 Inductor	1
L3	700uH	EE25 Inductor	1
Q1	2SK4086	Transistor, MOSFET 600V, 11A	1
R1,R11,R42	100K	Resistor 1/4W	3
R2	1.1MEG	Resistor 1/4W	1
R3	100	Resistor 1/4W	1
R4	200K	Resistor 1/4W	1
R5, R6	510K	Resistor 1/4W	2
R12	0	Resistor 1/4W	1
R14	10	Resistor 1/4W	1
R17	0.47/1W	Resistor 1W	1
R18	6.2K	Resistor 1/4W	1
R19	VR2K	VR Resistor	1
SZ1	12V/1W	Zener Diode 1W	1
U1	M8128	IC, Power Factor Controller	1

* All specs and applications shown above subject to change without prior notice.

(以上電路及規格僅供參考,本公司得逕行修正)