



PIR CONTROLLER

GENERAL DESCRIPTION 功能敘述

The M7612 is a PIR (passive infra-red) controller , using analog mixing digital design technique and manufactures by CMOS Process which can either drive TRIAC or RELAY depending on user’s choice. With special noise immunity technique , M7612 is the most stable PIR controller you can find on the market. More than this , there are few components needed in its application circuit which can reduce material cost and increase competitive.

FEATURES 產品特長

- High noise immunity.
- Drive either RELAY or TRIAC.
- Adjustable light on duration.
- TRIAC can be either shunt or serial connected.
- PIR input.
- CDS input.
- Auto change on / auto mode by bonding option.
- 16 pin DIP or SOP package.

APPLICATIONS 產品應用

- PIR light controller, Motion Detector, Alarm system, Auto-door bell.

PIN ASSIGNMENT

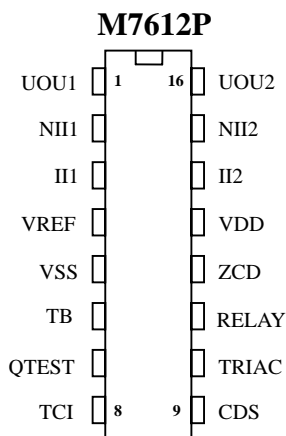



PIR CONTROLLER

PIN DESCRIPTION

Pin No	Pin Name	Description
1	UOU1	First stage OP amp output.
2	NII1	First stage OP amp positive input.
3	II1	First stage OP amp negative input.
4	VREF	Stable reference voltage.
5	VSS	System ground.
6	TB	Time base for : The delay time of receiving PIR signal to sent a pulse to trigger TRIAC or a high signal to trigger relay. The delay time = $R * C * 32$. The PIR signal patented and accepted only if the signal cycle greater than $R * C * 768$. When state of RELAY or TRIAC is changing form active into inactive mode. It takes more than $R * C * 4069$, then system is able to receive PIR signal again. $10K < R < 1M\Omega$ $100pF \leq C < 0.1\mu F$ (Reference Diagram 1)
7	QTEST	For testing only.
8	TCI	To set up the timing of how long TRIAC or RELAY is active. During the period , if the system receives the PIR signal , then it restarts counting the timing again. The flash cycle show the beginning of auto mode. Note : width of TRIAC pulse = $R * C * 2$ Flash cycle : $R * C * 32768$ The range for R : $4.7K \leq R < 1M\Omega$ $C : 100pF < C < 0.1\mu F$ (Reference Diagram 2)
9	CDS	Connected to a CDS for inhibiting RELAY or TRIAC being triggered. If TRIAC or RELAY has already being triggered by PIR signal and turned into active mode , then CDS can not inhibit PIR again.
10	TRAIC	To trigger TRIAC , active low. Sink current : 15 mA max.
11	RELAY	To drive relay , active high. Sink current : 10 mA max. Source current : 10 mA max.
12	ZCD	Detect zero cross of AC line under remote mode function.
13	VDD	Operation voltage : 5V , stand by current : 0.5 mA
14	II2	2 nd stage OP amp negative input.
15	NII2	2 nd stage OP amp positive input.
16	UOU2	2 nd stage OP amp output.



PIR CONTROLLER

DIAGRAM 1 :

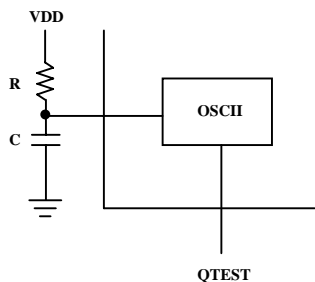
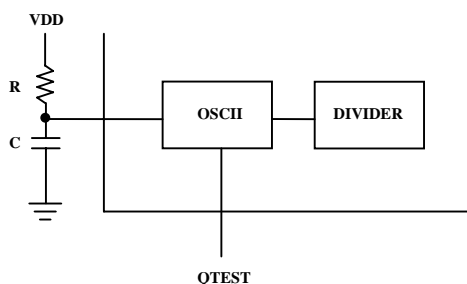
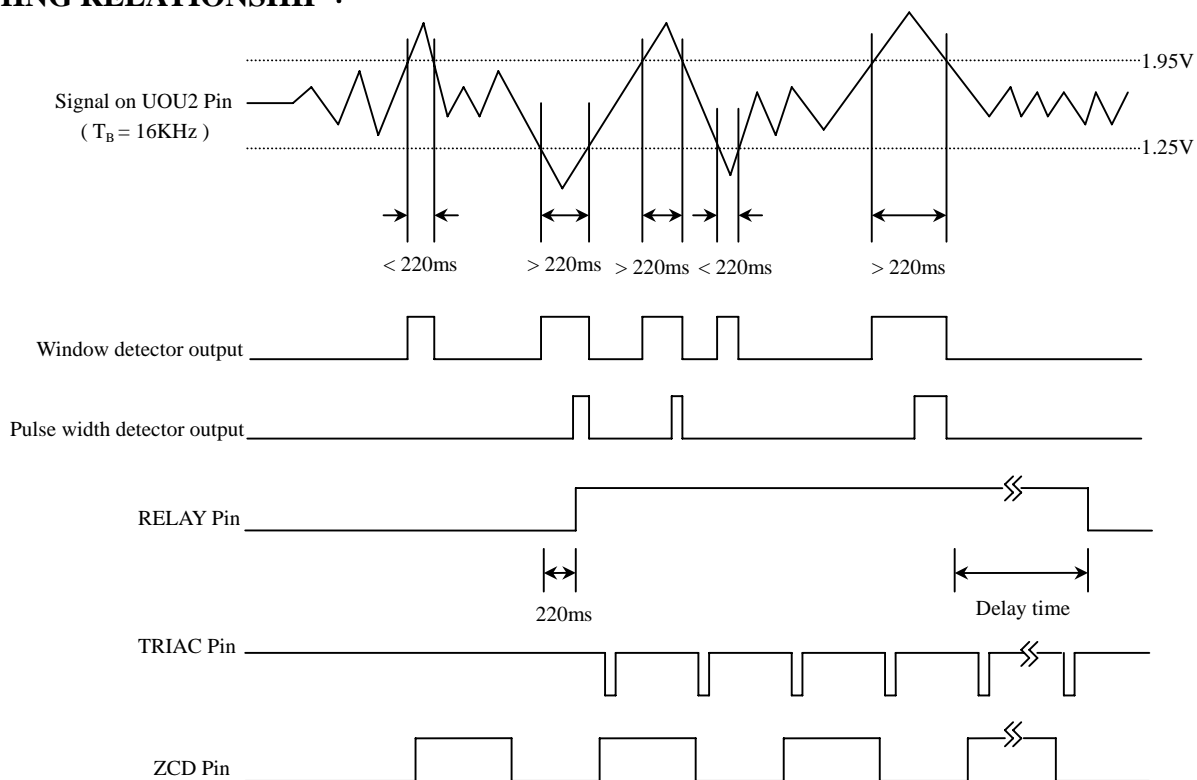

DIAGRAM 2 :



TIMING RELATIONSHIP :





PIR CONTROLLER

BLOCK DIAGRAM

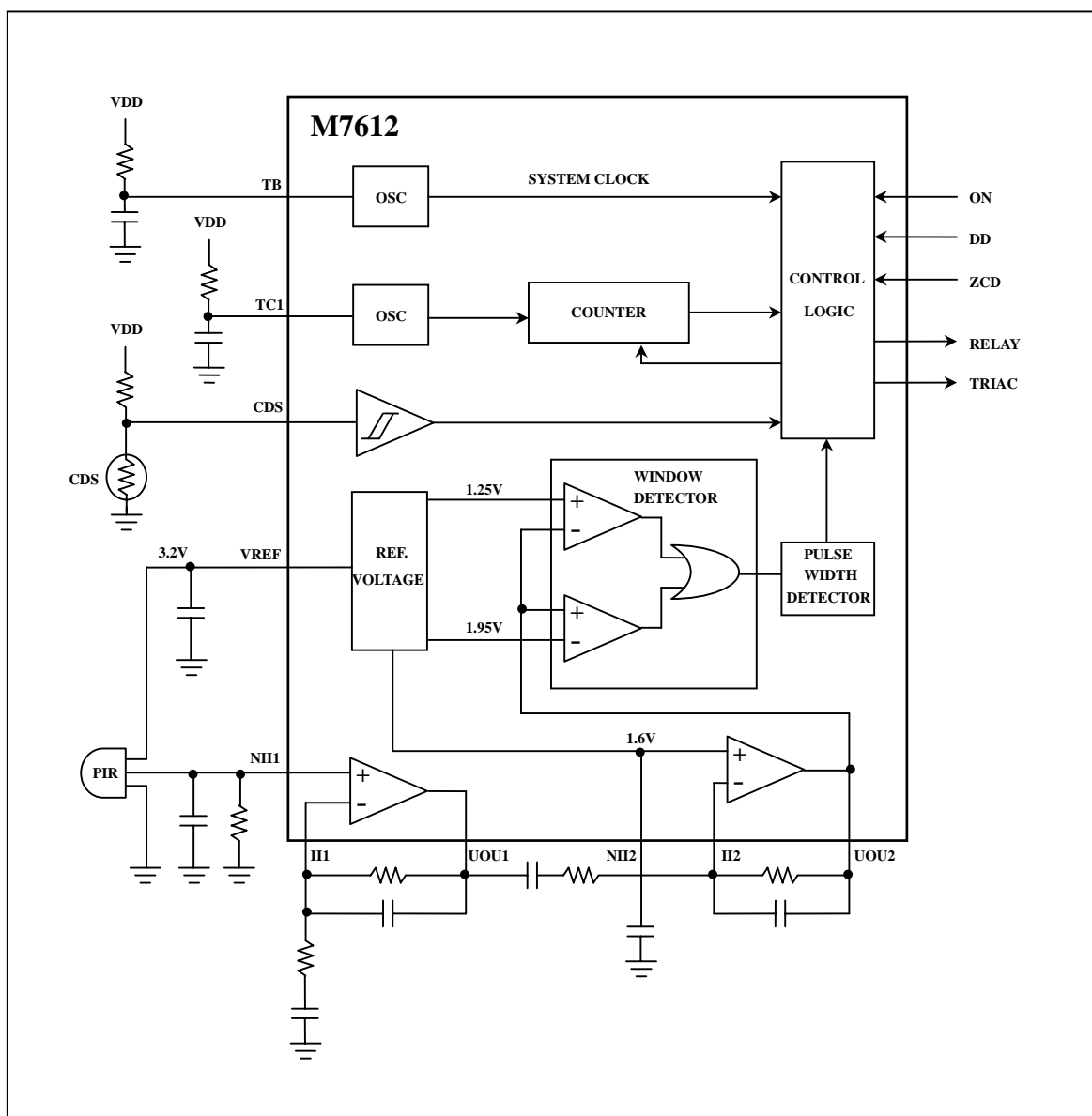



PIR CONTROLLER

ABSOLUTE MAXIMUM RATING

(TA=25°C)

Parameter	Sym.	Rating	Unit
Power Supply V_{DD} With Respect to V_{SS}	$V_{DD} - V_{SS}$	5.6	V
Voltage On Any Pin		-0.3 to 5.6	V
Operating Temperature	Top	-20 to 70	°C
Storage Temperature		-65 to 150	°C

ELECTRICAL CHARACTERISTICS

Characteristics	Sym.	Min.	Typ.	Max.	Unit	Conditions
Supply Voltage	V_{DD}	4.2	5	5.5	V	
Stand by Current	I_{ST}	0.9	1.0	1.2	mA	
Operating Current	I_{DD}	1.8	—	2.5	mA	1.8mA , TRIAC / 2.5mA , RELAY
Stable Voltage	V_{REF}	3.0	3.2	3.4	V	$V_{DD} > 4.2V$
Source Current of V_{REF}	I_{REF}	200	—	—	uA	
Ripple of V_{REF}		—	—	0.5	mV	
Input and Output Regulation of V_{REF}		—	—	0.3%		
Time Base Operating Frequency	F_{TB}	15	16	17	KHz	
CDS Operating Trigger	V_{T+}	1.3	1.7	2.1	V	
CDS Operating Trigger	V_{T-}	0.6	0.9	1.1	V	
CDS Output Sink Current	I_{SINK}	11.6	13	21	mA	
Timer Duration of Out 1	T_{OUT1}	10	—	1300	SEC	C=0.01uF , R=4.7K-1M
		0.1	—	13		C=100pF , R=4.7K-1M
Relay Source Current	I_{RS}	—	—	10	mA	
Relay Sink Current	I_{RSINK}	—	—	10	mA	
Relay Operating Voltage	V_{RO}	13.1	—	18.8	V	
TRIAC Sink Current	I_{TSINK}	—	—	15	mA	
TRIAC Source Current	$I_{TSOURCE}$	—	—	50	uA	



PIR CONTROLLER

ELECTRICAL CHARACTERISTICS 電氣規格

一. RELAY APPLICATION

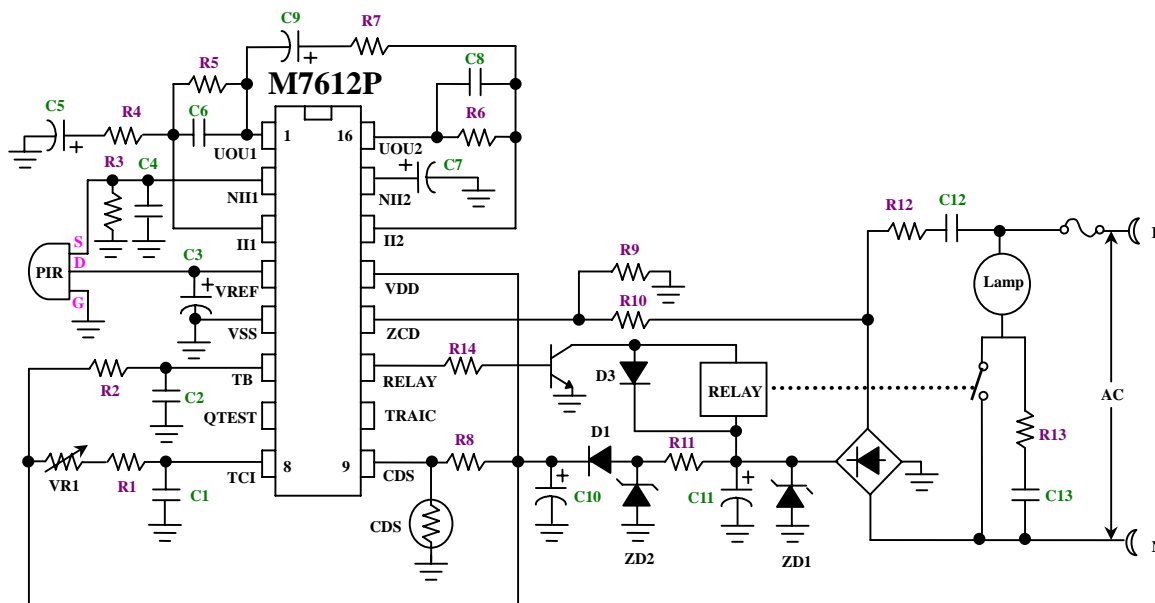

C1	0.01uF	VR1	1MΩ	R13	100Ω / 1/2W
C2	100pF	R1	4.7KΩ	R14	5.6KΩ
C3	100uF	R2	620KΩ	D1	1N4001
C4	0.01uF	R3	47KΩ	D3	1N4148
C5	33uF	R4	15KΩ	ZD1	12V
C6	0.1uF	R5	820KΩ	ZD2	5.6V
C7	47uF	R6	560KΩ		
C8	0.047uF	R7	15KΩ		
C9	47uF	R8	51KΩ		
C10	100uF/10V	R9	470KΩ		
C11	220uF/25V	R10	1MΩ		
C12	0.47uF/400~600V	R11	2.4KΩ		
C13	0.047uF/400~600V	R12	47Ω / 1/2W		

M7612 TCI PIN 外加電阻、電容與 Delay 時間的關係

電容	電阻	頻率	DELAY 時間(秒)
103	4.7K	40KHz	10
103	10K	20KHz	16
103	20K	10KHz	28
103	100K	2KHz	130
103	200K	0.8KHz	260
103	1M	0.2KHz	1300

Note :

(1) To adjust delay time , change VR1 value. (VR1=1M , delay time is ≥ 10 sec)

(2) For different CDS , R8 value should be adjusted.



PIR CONTROLLER

二. TRIAC APPLICATION

(A) 應用一

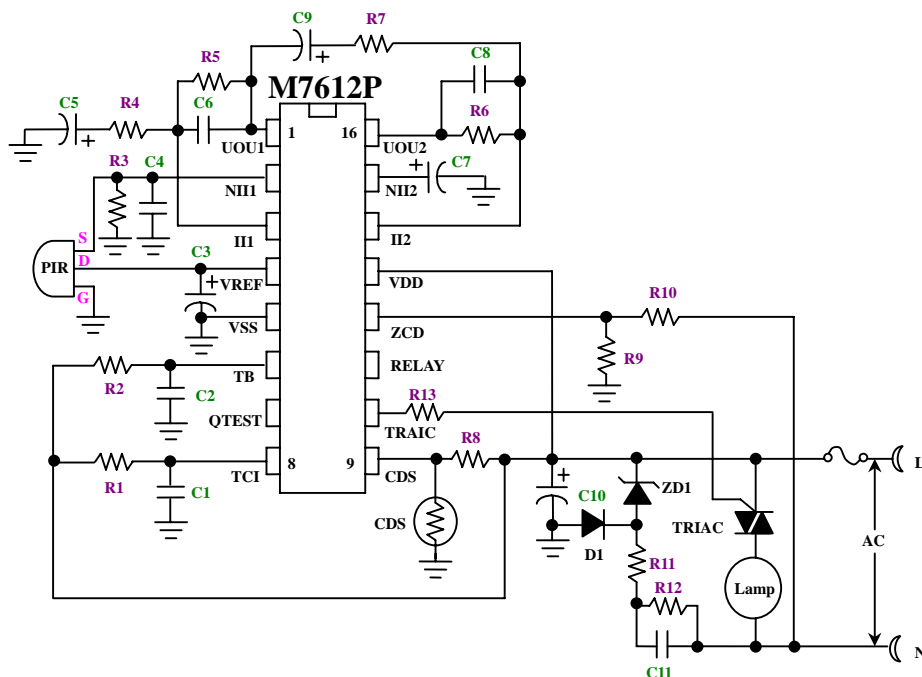

C1	0.01uF	R1	見附表
C2	100pF	R2	620KΩ
C3	100uF	R3	47KΩ
C4	0.01uF	R4	15KΩ
C5	33uF	R5	820KΩ
C6	0.1uF	R6	560KΩ
C7	47uF	R7	15KΩ
C8	0.047uF	R8	51KΩ
C9	47uF	R9	470KΩ
C10	100uF/10V	R10	1MΩ
C11	0.1uF/400~600V	R11	47Ω/ 1/2W
D1	1N4004	R12	100KΩ
ZD1	5.6V	R13	330Ω

M7612 TCI PIN 外加電阻、電容與 Delay 時間的關係

電容	R1 電阻	頻率	DELAY 時間(秒)
103	4.7K	40KHz	10
103	10K	20KHz	16
103	20K	10KHz	28
103	100K	2KHz	130
103	200K	0.8KHz	260
103	1M	0.2KHz	1300

Note :

- (1) To adjust delay time , change R1 value. (Delay time is ≥ 10 sec)
- (2) For different CDS , R8 value should be adjusted.



PIR CONTROLLER

(B) 應用二

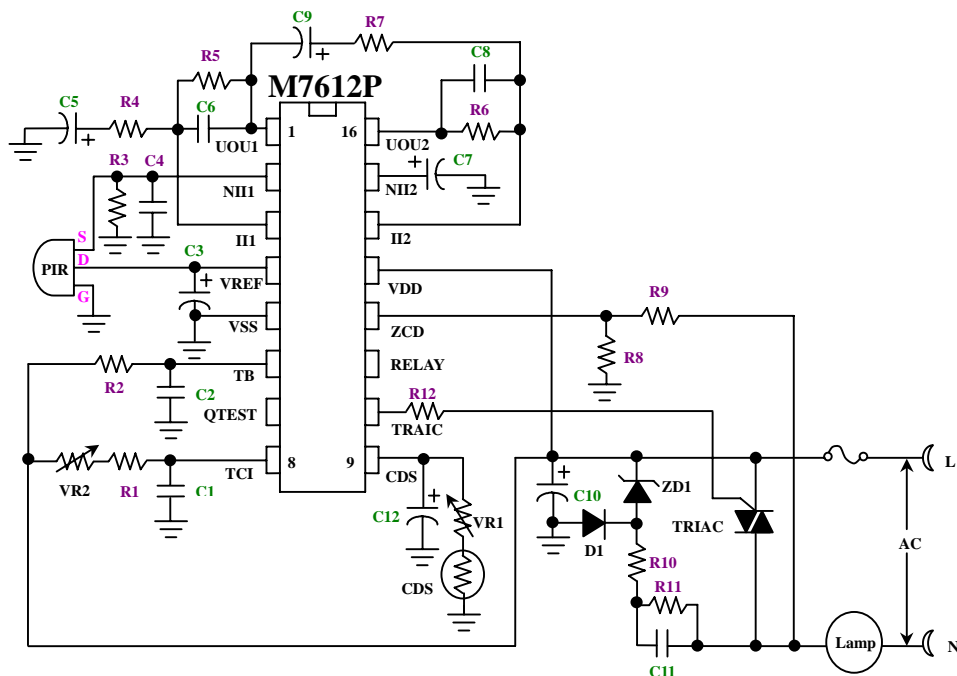

C1	0.01uF	VR1	1MΩ
C2	100pF	VR2	1MΩ
C3	100uF / 16V	R1	4.7KΩ
C4	0.01uF	R2	620KΩ
C5	220uF / 10V	R3	47KΩ
C6	0.1uF	R4	47KΩ
C7	22uF / 16V	R5	220KΩ
C8	683 pF	R6	470KΩ
C9	47uF / 16V	R7	56KΩ
C10	470uF / 16V	R8	800KΩ
C11	0.15uF / 400~600V	R9	720KΩ
C12	1uF / 50V	R10	47Ω / 1/2W
D1	1N4007	R11	100KΩ
ZD1	6.2V	R12	100Ω

M7612 TCI PIN 外加電阻、電容與 Delay 時間的關係

電容	電阻	頻率	DELAY 時間(秒)
103	4.7K	40KHz	10
103	10K	20KHz	16
103	20K	10KHz	28
103	100K	2KHz	130
103	200K	0.8KHz	260
103	1M	0.2KHz	1300

Note :

- (1) To adjust delay time , change VR2 value. (VR2=1M , delay time is ≥ 10 sec)
- (2) For different CDS , VR1 value should be adjusted.
- (3) Distance = 4m.



PIR CONTROLLER

(C) 應用三

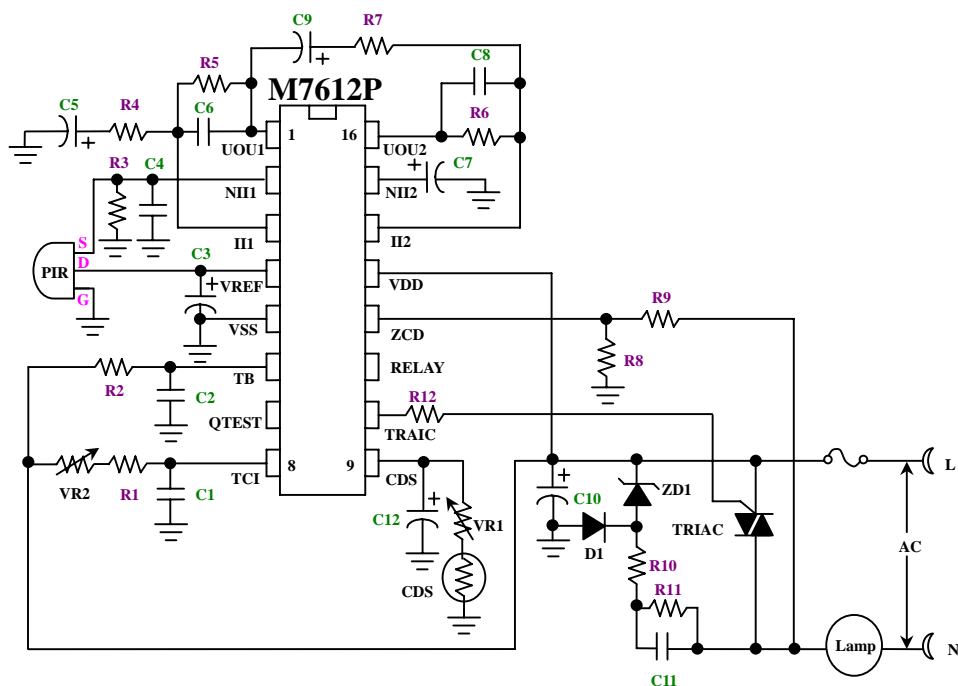

C1	0.01uF	VR1	1MΩ
C2	100pF	VR2	1MΩ
C3	100uF / 16V	R1	4.7KΩ
C4	0.01uF	R2	620KΩ
C5	33uF / 16V	R3	47KΩ
C6	0.033uF	R4	15KΩ
C7	22uF / 16V	R5	820KΩ
C8	0.033 uF	R6	820KΩ
C9	33uF / 16V	R7	15KΩ
C10	470uF / 16V	R8	800KΩ
C11	0.33uF / 400~600V	R9	720KΩ
C12	1uF / 50V	R10	47Ω / 1/2W
D1	1N4007	R11	100KΩ
ZD1	6.2V	R12	100Ω

M7612 TCI PIN 外加電阻、電容與 Delay 時間的關係

電容	電阻	頻率	DELAY 時間(秒)
103	4.7K	40KHz	10
103	10K	20KHz	16
103	20K	10KHz	28
103	100K	2KHz	130
103	200K	0.8KHz	260
103	1M	0.2KHz	1300

Note :

- (1) To adjust delay time , change VR2 value. (VR2=1M , delay time is ≥ 10 sec)
- (2) For different CDS , VR1 value should be adjusted.
- (3) Distance = 8m.

* All specs and applications shown above subject to change without prior notice.
(以上電路及規格僅供參考,本公司得逕行修正)