



## GENERAL DESCRIPTION 功能敘述

The M3EB is a CMOS ASIC decoder. It will en-code 12 parallel input and serially transmit them to the output when D0 ~ D3 depressed. Paired with either M3D or M3DB. These address inputs are 3 states i.e. LOW(0) 、 OPEN(X) 、 HIGH(1).

## FEATURES 產品特長

- Built-in IR carrier : suffix-I.
- Up to  $3^{10}$  =59,049 codes, "0" 、 "X" 、 "1" Tri-states.
- Single resistor oscillator.
- Data transmit over 30 second auto power off.
- 2 or 4 direct date transmit ( internal pull-low resistor ).
  - M3EB-2 : 10 address , 2 data.
  - M3EB-4 : 8 address , 4 data.

## APPLICATIONS 產品應用

- Car/home alarm system, garage control etc..

## BLOCK DIAGRAM 功能方塊圖

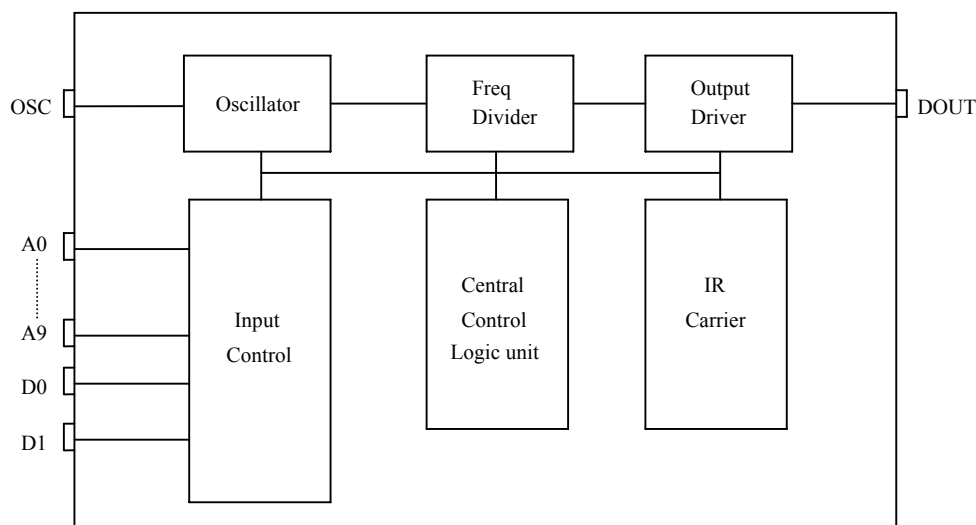

\*All specs and applications shown above subject to change without prior notice.  
( 以上電路及規格僅供參考,本公司得逕行修正 )



3 STATES ENCODER  
3 態編碼 IC

EN/DECODER

**M3EB**

**ABSOLUTE MAXIMUM RATING**

(TA=25°C)

Parameter	Rating	Unit
Supply Voltage	-0.3 to 12	V
Input Voltage	-0.2~V <sub>DD</sub> +0.2	V
Operating Temperature	-20 to 70	°C
Storage Temperature	-50 to 125	°C

**ELECTRICAL CHARACTERISTICS**

Characteristics	Sym.	Min.	Typ.	Max.	Unit	Conditions
Operating Voltage	V <sub>DD</sub>	2.4	—	12	V	
Operating Current	I <sub>OP</sub>	—	0.3	1	mA	No load
Quiescent Current	I <sub>SB</sub>	—	1	10	uA	
Output Drive Current	I <sub>O</sub>	—	2	—	mA	@V <sub>DS</sub> =1.2V
Input Voltage	V <sub>IH</sub>	V <sub>DD</sub> -0.2	V <sub>DD</sub>	V <sub>DD</sub>	V	
	V <sub>IL</sub>	V <sub>SS</sub>	V <sub>SS</sub>	V <sub>SS</sub> +0.2		
Oscillator Frequency	F <sub>osc</sub>	—	152	—	KHz	External±30%, Rosc=470KΩ

**PIN DESCRIPTION**

No.	M3EB	Description
1~8	A0~A7	3 states address inputs
9	VSS	Negative power supply
10~11	A8/D0, A9/D1	3 states address inputs
12~13	D2, D3	Direct data transmission enable
14	OSC	Oscillator input
15	DOUT	Data output
16	VDD	Positive power supply

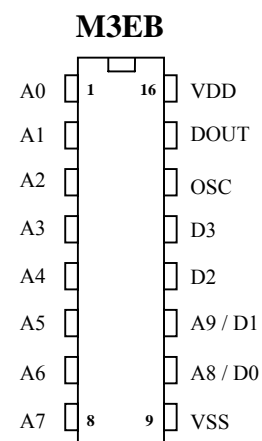



## TIMING WAVEFORM

### (1) Bit format

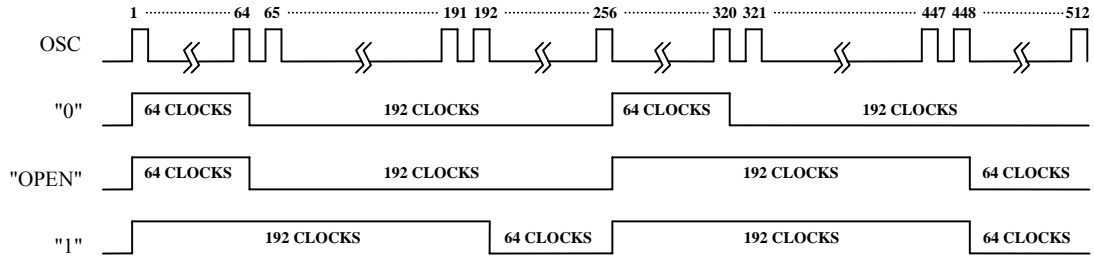

### (2) TIMING DIAGRAM

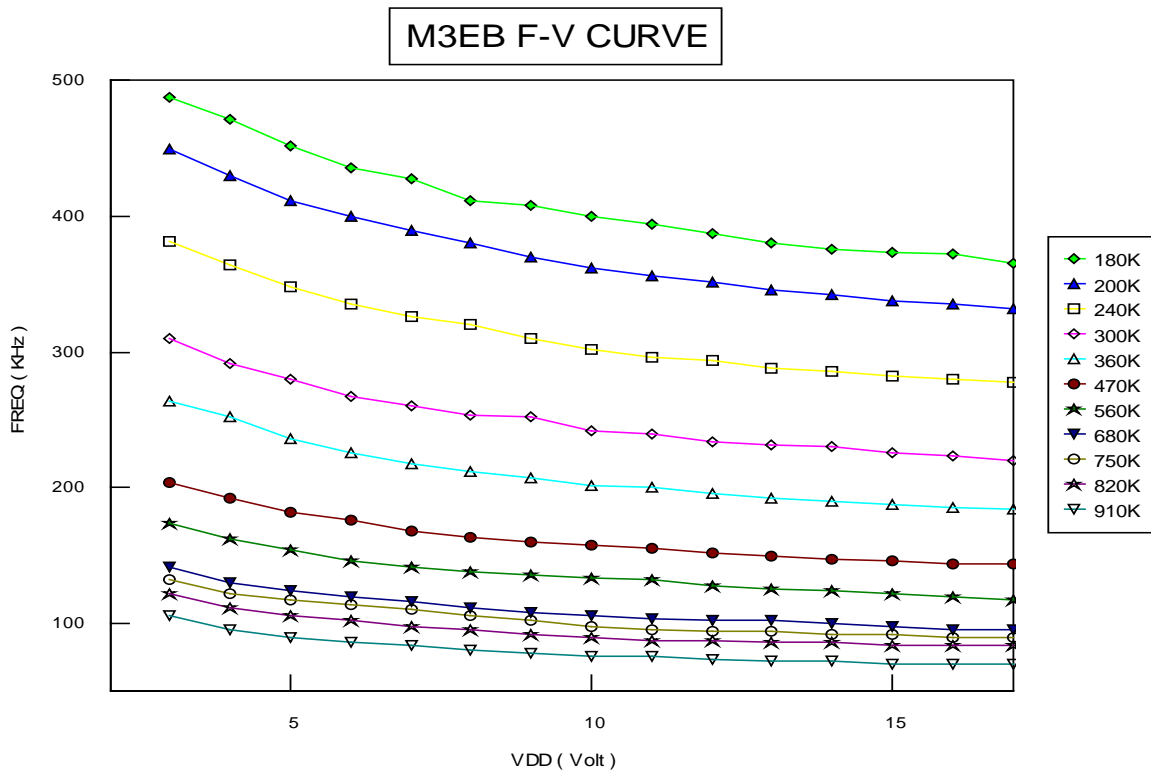
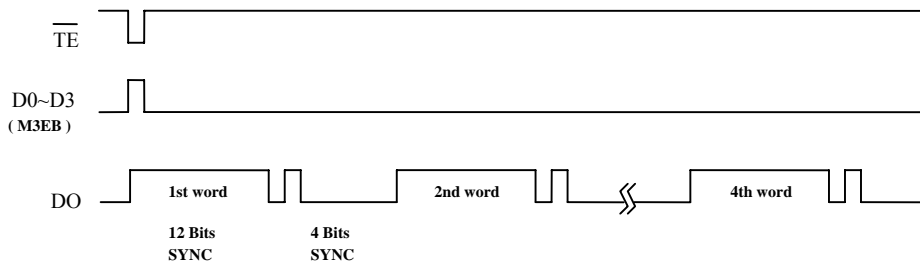



EN/DECODER
<b>M3EB</b>

**OPERATING FLOWCHART**

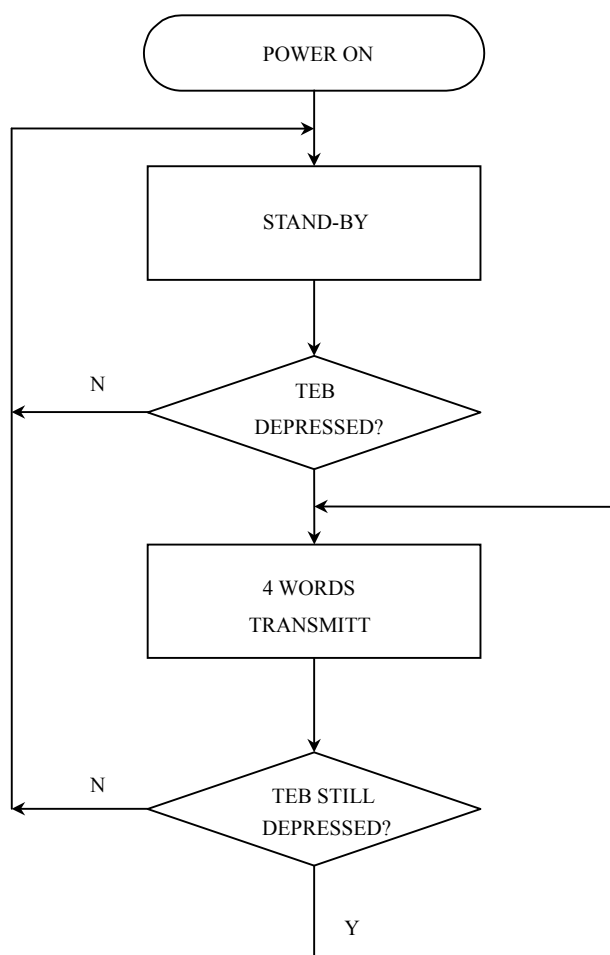



3 STATES ENCODER  
3 態 編 碼 IC

EN/DECODER

**M3EB**

**RECONNENDED OSCILLATOR PARAMETERS**

Rosc (K $\Omega$ )	M3EB (KHz)
180	388
200	352
240	294
300	234
360	196
470	152
560	128
680	102
750	94
820	88
910	74

**DATA OUTPUT**

M3EB (D0~D3)	M3DB (D0~D3)
X (OPEN)	0 (VSS)
1 (VDD)	1 (VDD)
POWER ON	0 (VSS)

**Freq-Rosc Chart**

( @Vdd = 12V )

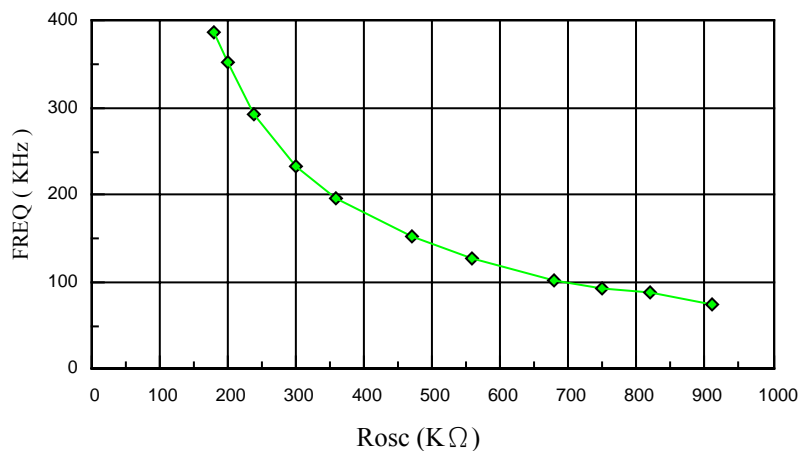

◆ M3EB



APPLICATION DIAGRAM 參考電路圖

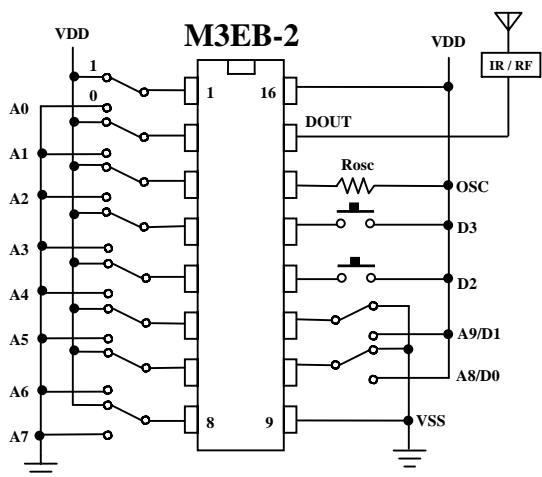

IR 內建發射

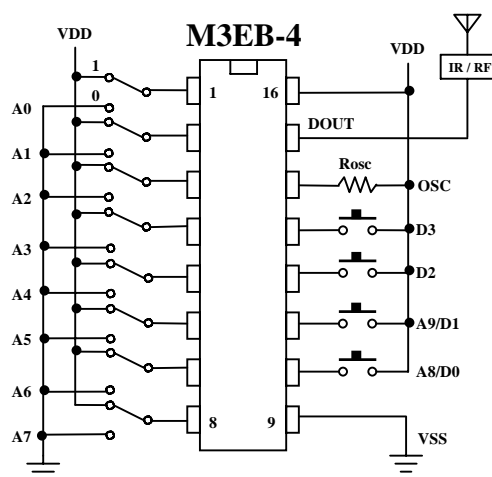

IR 內建發射

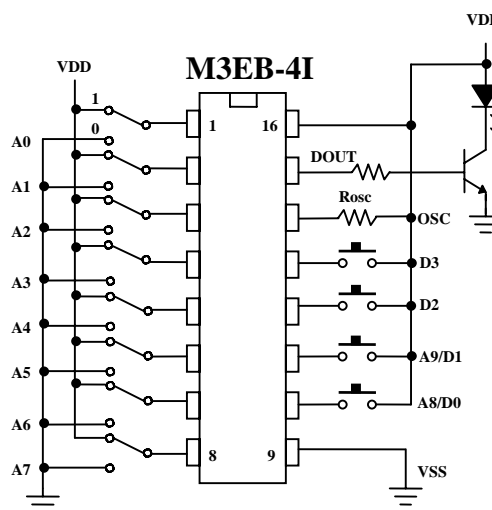
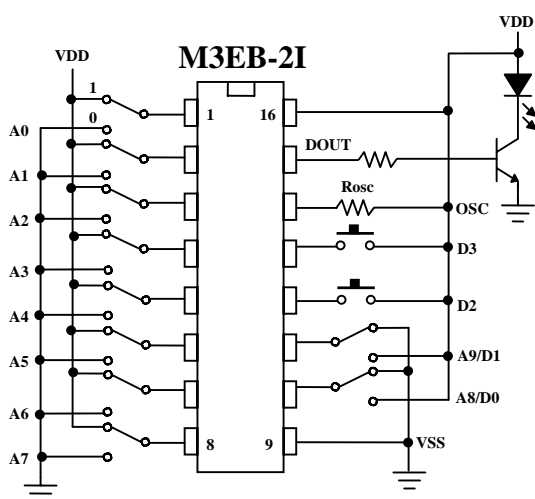



APPLICATION DIAGRAM 參考電路圖 (SOP PACKAGE)

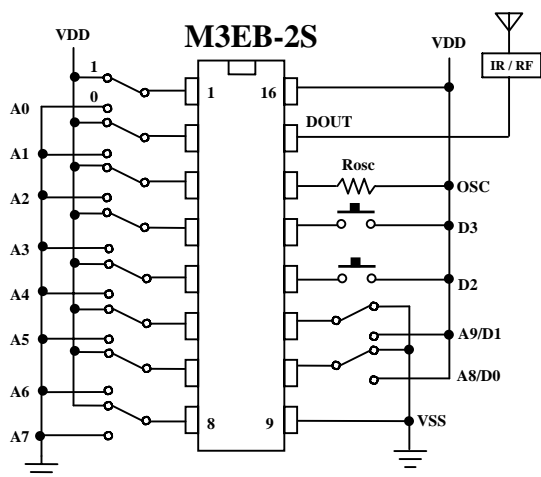

IR 內建發射

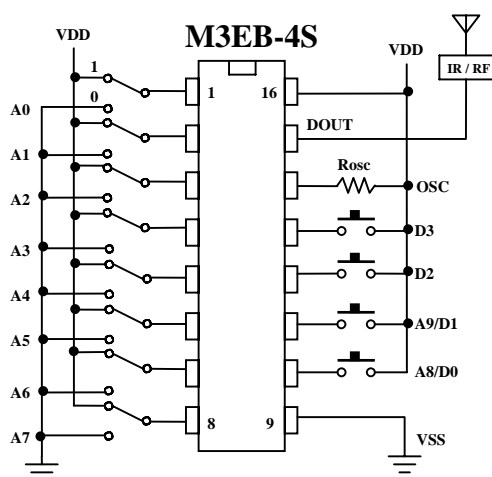

IR 內建發射

