



## 2<sup>20</sup> OTP ENCODER

### GENERAL DESCRIPTION

The M320EB is a 2<sup>20</sup> services of encoder pair with M320D utilizing CMOS LSI design for use in remote control system. The M320EB is design by a one-time programmable process. They decide the transmission word of M320EB that compose of 4 data bits, 20 address bits. A transmission word of the M320EB is transmitted on the DO pin via an RF transmission medium upon receipt of a trigger signal.

### FEATURES

- 4 direct data input pins, Up to 15 data combination.
- 12 seconds auto transmission out off to reduce power consumption.
- Up to 2<sup>20</sup> (1,048,576) address codes.
- An external oscillation resister.
- One-time programmable process.
- Available in SOP or DIP package.

### APPLICATIONS

- Burglar alarm system, car door controllers, car alarm system, home/office security system...etc.

### BLOCK DIAGRAM

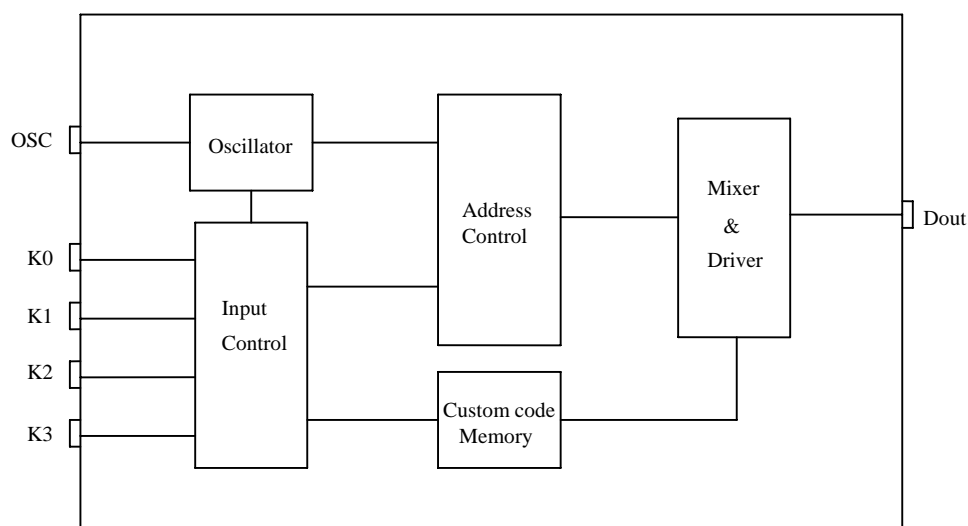



**2<sup>20</sup> OTP ENCODER**

**ABSOLUT MAXIMUM RATING**

Parameter	Rating	Unit
Supply Voltage	2.4 to 12	V
Input Voltage	-0.7~V <sub>DD</sub> +0.3	V
Operating Temperature	-20 to 70	°C
Storage Temperature	-55 to +125	°C

**ELECTRICAL CHARACTERISTICS**

Characteristics	Sym.	Min.	Typ.	Max.	Unit	REMARKS
Operating Voltage	V <sub>DD</sub>	2.4	—	12	V	
Operating Current	I <sub>OP</sub>	—	0.3	—	mA	No load
Quiescent Current	I <sub>SB</sub>	—	1	3	μA	@V <sub>DS</sub> =1.2V
Input Voltage	V <sub>IH</sub>	0.7V <sub>DD</sub>	—	V <sub>DD</sub>	V	
	V <sub>IL</sub>	0	—	0.3V <sub>DD</sub>		
Output Current	I <sub>O</sub>	—	2	—	mA	
Oscillator Frequency	F <sub>osc</sub>	—	80	—	KHz	External±30%, R <sub>osc</sub> =300KΩ

**PIN DESCRIPTION**

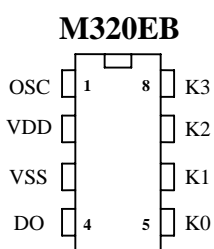

NO.	Name	I/O	Description
1	OSC	I	Oscillator input pin
2	VDD	—	Positive power supply
3	VSS	—	Negative power supply (GND)
4	DO	O	Encoder data serial transmission output
5	K0	I	Input pin D0 setting and transmission output
6	K1	I	Input pin D1 setting and transmission output
7	K2	I	Input pin D2 setting and transmission output
8	K3	I	Input pin D3 setting and transmission output



**2<sup>20</sup> OTP ENCODER**

**CODE FORMAT**

**(1) Bit format**

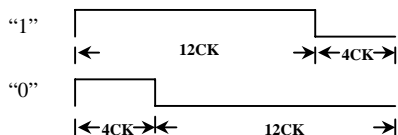

DEFINITE : 1CK= 8 OSC CLKS WIDTH

**(2) Output Data Frame**

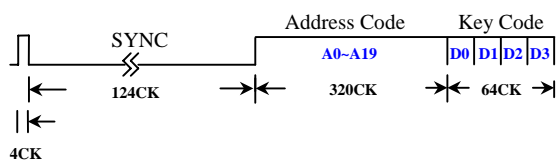

**(3) K0~K3 Combination Table**

KEY				DATA			
K3	K2	K1	K0	D3	D2	D1	D0
0	0	0	1	0	0	0	1
0	0	1	0	0	0	1	0
0	0	1	1	0	0	1	1
0	1	0	0	0	1	0	0
0	1	0	1	0	1	0	1
0	1	1	0	0	1	1	0
0	1	1	1	0	1	1	1
1	0	0	0	1	0	0	0
1	0	0	1	1	0	0	1
1	0	1	0	1	0	1	0
1	0	1	1	1	0	1	1
1	1	0	0	1	1	0	0
1	1	0	1	1	1	0	1
1	1	1	0	1	1	1	0
1	1	1	1	1	1	1	1

Note : 1 = VDD

0 = VSS



**2<sup>20</sup> OTP ENCODER**

**SINGLE RESISTOR OSCILLATOR**

The typical oscillator frequency with various resistor values for M320EB is given below :

**Encoder (M320EB) Oscillator Frequency**

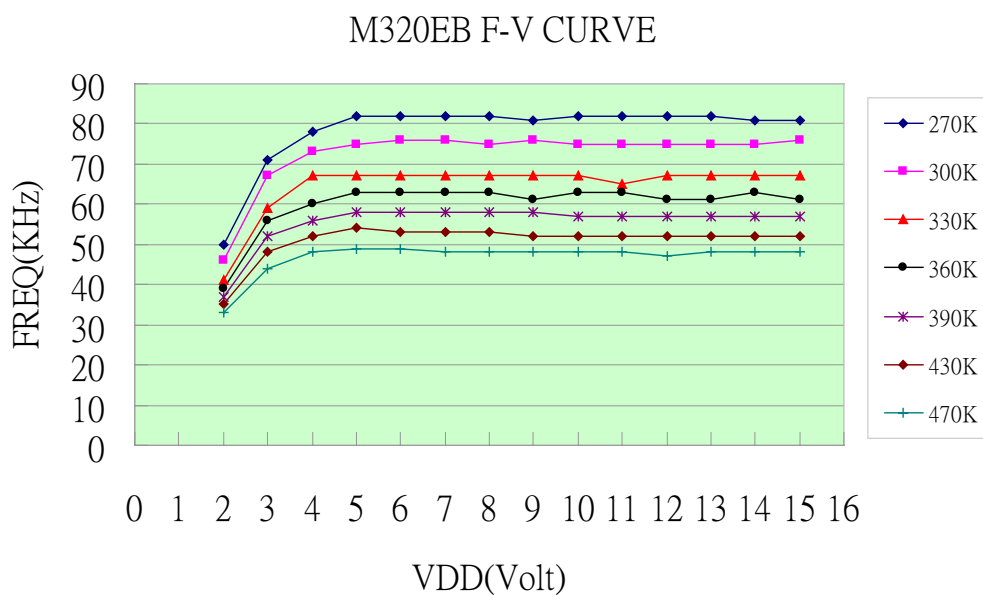

**APPLICATION DIAGRAM**

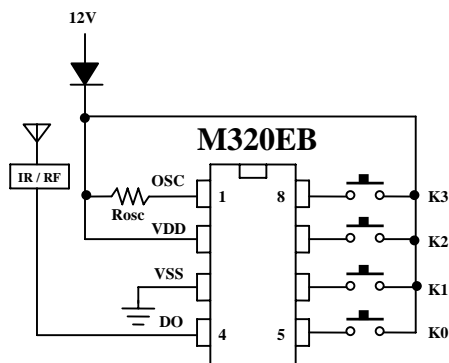

\*All specs and applications shown above subject to change without prior notice.  
( 以上電路及規格僅供參考,本公司得逕行修正 )