



**CHARGE-TRANSFER TOUCH SENSOR**  
連續, 開/關調光器

Dimmer
<b>M7236</b>

## GENERAL DESCRIPTION 功能敘述

M7236 is a self-contained digital IC capable of detecting near-proximity or touch. It will project a proximity sense field through air, via almost any dielectric, like glass, plastic, stone, ceramic, and most kinds of wood. It can also turn small metal-bearing objects into intrinsic sensors, making them responsive to proximity or touch. This capability coupled with its ability to self calibrate continuously can lead to entirely new product concepts.

It is designed specifically for human interfaces, like control panels, appliances, toys, lighting controls, or anywhere a mechanical switch or button may be found; it may also be used for some material sensing and control applications provided that the presence duration of objects does not exceed the recalibration timeout interval.

The brightness of the output is controlled by applying a high level at the TI input. The LED indicated that Sensitivity adjusted via resistor value easily. Function is implemented with very few interface components.

If the sensor is touched momentarily (50ms to 350ms), lamp is:

- (a) Turned off if it was on.
- (b) Turned on if it was off. The brightness resulting is either full brightness or depending on the circuit type, previous brightness stored in the IC memory.

If the sensor is touched more than 350ms the light intensity changes slowly. As long as the touch is maintained, the change continues; the direction of change reverses whenever the maximum or minimum brightness is reached.

## FEATURES 產品特長

Project a proximity field through air.

Provides brightness control of incandescent lamps with touch plates or pushbutton control.

Sensitivity easily adjusted via resistor value.

Control the duty cycle from 22% to 97% (conduction angles for AC half-cycle between 40° and 175°, respectively)

Operates at 50Hz/60Hz line frequency.

8 pin DIP package

## APPLICATIONS 產品應用

Light switch, pointing device, appliance control, Toys & games.

## PIN ASSIGNMENT

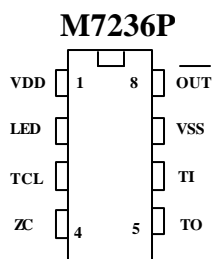



**CHARGE-TRANSFER TOUCH SENSOR**  
連續，開/關調光器

Dimmer
<b>M7236</b>

**PIN DESCRIPTION**

Pin No.	Pin Name	Description
1	VDD	Positive power supply
2	LED	M7236-1 : for touch sensitivity of the TI input indicator. M7236-2 : for night indicator.
3	TCL	Test pin.
4	ZC	The AC Line Frequency is applied to this input through an external RC circuit. The Phase-Lock Loop in the IC synchronizes all internal timings to the AC signal at the ZC input.
5	TO	Set up the sensitivity of the TI input.
6	TI	A high level activates this input which controls the turn-on, turn-off and conduction angle $\emptyset$ of the TI signal with respect to the ZC input. see <b>SENSOR DURATION TABLE</b> .
7	VSS	Negative power supply
8	OUT	The output is a low level pulse occurring once every half-cycle of the ZC input. The conduction angle $\emptyset$ of the output in relation to the ZC signal controls the lamp brightness.

The functional differences of different versions of the light dimmer ICs are explained in below Table

<b>SENSOR / TOUCH DURATION TABLE</b>				Dimming Direction Reversal
Momentary (50ms to 350ms) * Note 1		Prolonged (more than 350ms) * Note1		
Pre-Touch $\emptyset$	Post-Touch $\emptyset$	Pre-Touch $\emptyset$	Post-Touch $\emptyset$	
Off	Memory * Note 2	Off	Starts varying at Memory * Note 3	Yes
Max.	Off	Max.	Starts varying at Max	N/A
Intermediate	Off	Intermediate	Starts varying at Pre-Touch brightness	Yes

Note1 : The timings are based on  $F_s = 60\text{Hz}$ , unless otherwise specified. 50Hz timings are 1.2 times 60Hz timings.

Note2 : "Memory" refers to the conduction angle,  $\emptyset$  which existed prior to the current off-state. First time after power-up, the Memory value defaults to maximum conduction angle.

Note3 : First time after power-up, Long touch causes intensity to vary starting at minimum conduction angle.



**CHARGE-TRANSFER TOUCH SENSOR**  
連續, 開/關調光器

Dimmer
<b>M7236</b>

**TIMING CHARACTERISTICS**

SYMBOL	PARAMETER	Min.	Typ.	Max.	Unit
Fs	AC Frequency	40	60	70	Hz
Ts1	Sensor duration(On/Off)	50		350	ms
Ts2	Sensor duration(Dimming)	350		Infinite	ms
TW	Output pulse width		33		us
Phase	Output phase $\emptyset$	40		175	degrees
	Max. to Max. dimming time		9.5		Sec
	A1B1=B2A2 duration		2		Sec
	B1B2 Min. intensity dwell		500		ms

\*All timings are based on Fs = 60Hz, unless otherwise specified. 50Hz timings are 1.2 times 60Hz timings.

**Output phase angle**

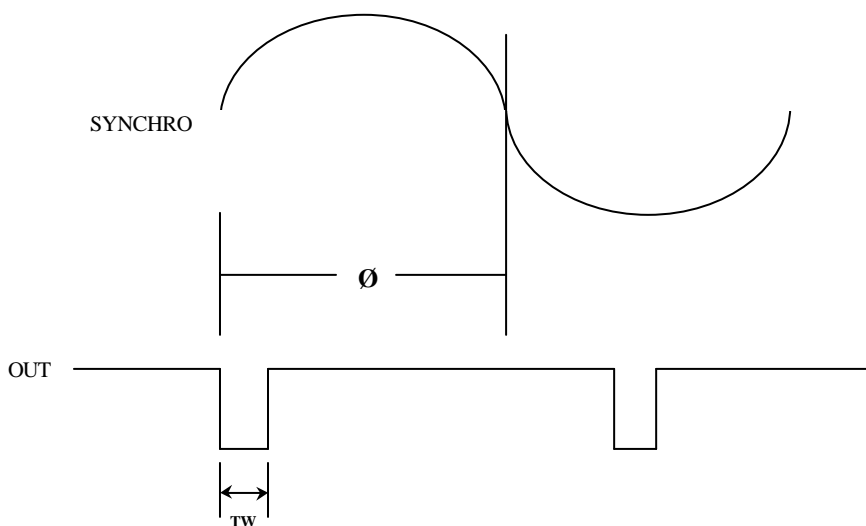

**Output phase-angle ( $\emptyset$ ) VS Sensor input**

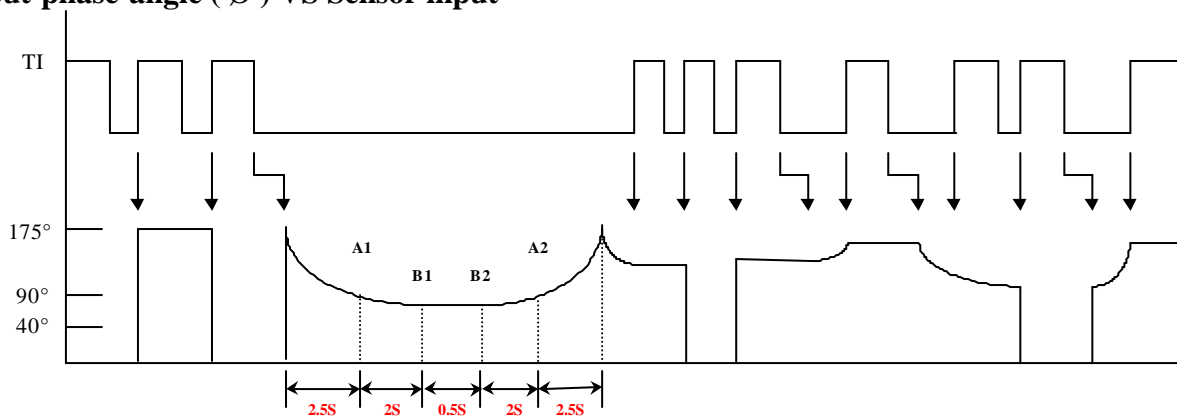

Note : Timing are indicated after initial Power-up.



CHARGE-TRANSFER TOUCH SENSOR  
連續，開/關調光器

Dimmer
M7236

BLOCK DIAGRAM

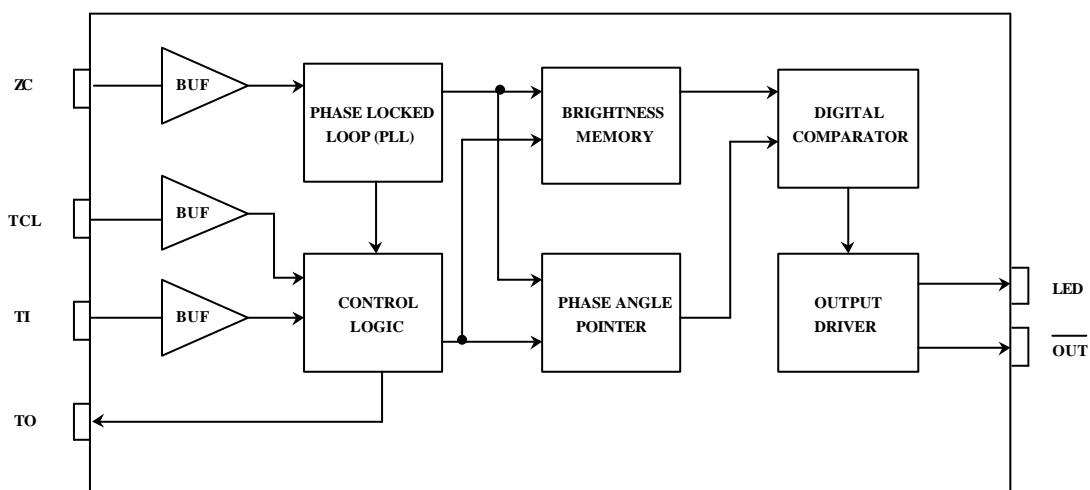

ELECTRICAL CHARACTERISTICS 電氣規格

(TA=25 )

Characteristics	Sym.	Min.	Typ.	Max.	Unit	Conditions
Supply Voltage	$V_{DD}$	3	4.5	5	V	
Operating Current	$I_{OP}$		2.5	3	mA	No load
Output Sink Current	$I_{SINK}$	—	10	—	mA	@ $V_{DD}=4.5V$
Operating Temperature	Temp.	0	25	60		
Storage Temperature	Temp.	-65	—	150		



**CHARGE-TRANSFER TOUCH SENSOR**  
連續，開/關調光器

Dimmer
<b>M7236</b>

## TOUCH SENSOR DESIGN

Touch sensor geometry and size: there is no restriction on the shape of the electrode; in most cases common sense and a little experimentation can result in a good electrode design. The M7236 will operate equally well with long, thin electrodes as with round or square ones; even random shapes are acceptable. The electrode can also be a 3-dimensional surface or object. Sensitivity is related to electrode surface area, orientation with respect to the object being sensed, object composition, and the ground coupling quality of both the sensor circuit and the sensed object.

If a relatively large electrode surface is desired, and if tests show that the electrode has more capacitance than the M7236 can tolerate, the electrode can be made into a sparse mesh having lower C than a solid plane. Sensitivity may even remain the same, as the sensor will be operating in a lower region of the gain curves.

## SENSITIVITY

The M7236 sensitivity change is made by altering the internal numerical threshold level required for a detection. Note that sensitivity is also a function of other things: the value of R5, electrode size, shape, and orientation, the composition and aspect of the object to be sensed, the thickness and composition of any overlaying panel material, and the degree of ground coupling of both sensor and object.

## INCREASING SENSITIVITY

In some cases it may be desirable to increase sensitivity further, for example when using the sensor with very thick panels having a low dielectric constant.

Sensitivity can often be increased by using a bigger TOUCH SENSOR, reducing panel thickness, or altering panel composition. Increasing electrode size can have diminishing returns, as high values of C (The human body naturally has several hundred picofarads of 'free space' capacitance to the local environment) will reduce sensor gain. The value of R5 also has a dramatic effect on sensitivity, and this can be increased in value (up to a limit). Also, increasing the electrode's surface area will not substantially increase touch sensitivity if its diameter is already much larger in surface area than the object being detected. The panel or other intervening material can be made thinner, but again there are diminishing rewards for doing so. Panel material can also be changed to one having a higher dielectric constant, which will help propagate the field through to the front. Locally adding some conductive material to the panel (conductive materials essentially have an infinite dielectric constant) will also help; for example, adding carbon or metal fibers to a plastic panel will greatly increase frontal field strength, even if the fiber density is too low to make the plastic bulk-conductive.

## DECREASING SENSITIVITY

In some cases the M7236 may be too sensitive, even on low gain. In this case gain can be lowered further by a number of strategies: making the electrode smaller, making the electrode into a sparse mesh using a high space-to-conductor ratio, or by decreasing R5.



Dimmer
M7236

**CHARGE-TRANSFER TOUCH SENSOR**  
連續，開/關調光器

**APPLICATION EXAMPLE**

A typical implementation of a lamp dimmer circuit is shown below. Here the brightness of the lamp is set by touching the SENSOR Plate. The functions of different components are as follows :

The 4.5V DC supply for the chip is provided by D1, R1, Z1, C2.

R2 for the ZC input for synchronizing the internal DPLL with the line frequency.

C3, C4, R5 set up the sensitivity of the TI input.

R4 provides current limiting and isolation between the chip output and the TRIAC gate.

C1 and L1 are RF filter circuits.

In the case of momentary power failure, the circuit state remains unchanged for a period of up to 1 sec.

For longer power interruptions, the output is shut off.

**APPLICATION DIAGRAM 參考電路圖**

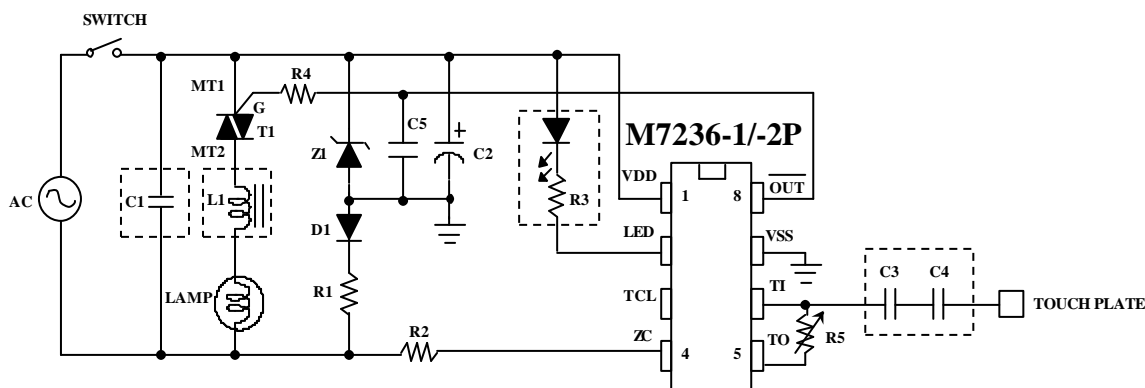

COMPONENT	110V	220V
C1	1μF/250V	1μF/250V
L1	100μH	220μH
Z1	4.3V/ 1/2W	4.3V/ 1/2W
D1	IN4004	IN4004
R1	10K /2W	20K /2W
C2	220μF/16V	220μF/16V
R2	1M	1M
R3	1K	1K
R4	330	330
R5	500K	500K
C3, C4, C5	0.1μF	0.1μF
T1	BTA04	BTA04

\* All specs and applications shown above subject to change without prior notice.  
(以上電路及規格僅供參考,本公司得逕行修正)